

IN485HIT001R000 Gateway for Hitachi Commercial and VRV Systems BACNET MS/TP AND MODBUS RTU SERVER GATEWAY

USER MANUAL
Version 2.0.6
Publication date 2024-02-26

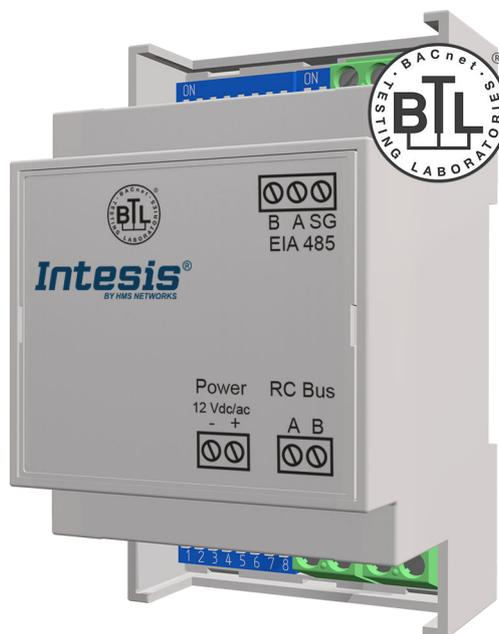

Copyright © 2023 Intesis

Disclaimer

The information in this document is for informational purposes only. Please inform HMS Networks of any inaccuracies or omissions found in this document. HMS Networks disclaims any responsibility or liability for any errors that may appear in this document.

HMS Networks reserves the right to modify its products in line with its policy of continuous product development. The information in this document shall therefore not be construed as a commitment on the part of HMS Networks and is subject to change without notice. HMS Networks makes no commitment to update or keep current the information in this document.

The data, examples and illustrations found in this document are included for illustrative purposes and are only intended to help improve understanding of the functionality and handling of the product. In view of the wide range of possible applications of the product, and because of the many variables and requirements associated with any particular implementation, HMS Networks cannot assume responsibility or liability for actual use based on the data, examples or illustrations included in this document nor for any damages incurred during installation of the product. Those responsible for the use of the product must acquire sufficient knowledge in order to ensure that the product is used correctly in their specific application and that the application meets all performance and safety requirements including any applicable laws, regulations, codes and standards. Further, HMS Networks will under no circumstances assume liability or responsibility for any problems that may arise as a result from the use of undocumented features or functional side effects found outside the documented scope of the product. The effects caused by any direct or indirect use of such aspects of the product are undefined and may include e.g. compatibility issues and stability issues.

Table of Contents

1. Description, Compatible AC systems, and Order Codes	1
2. General Information	2
2.1. Intended Use of the User Manual	2
2.2. General Safety Information	2
2.3. Admonition Messages and Symbols	2
3. Quickstart Guide for the IN485HIT001R000 Gateway	4
4. Overview	5
4.1. Inside the Package	6
4.2. Main Features	6
4.3. Gateway Capacity	6
4.4. General Functionality	6
5. Hardware	7
5.1. Connection Procedure	7
5.2. Connection to an External Power Supply	8
5.3. DIP Switches	9
5.4. LED Indicators	11
5.5. Technical Specifications	12
5.6. Dimensions	12
6. Restore the Factory Settings	13
7. BACnet Application Specifications	14
7.1. Objects	14
7.1.1. Supported Object Types	14
7.1.2. Member Objects	14
7.1.2.1. Type: Gateway	14
7.1.2.2. Type: Indoor Unit	14
7.1.3. Objects and Properties	15
7.1.3.1. Hitachi AC Gateway (Device Object Type)	15
7.1.3.2. OnOff_status (Binary Input Object Type)	17
7.1.3.3. OnOff_command (Binary Output Object Type)	18
7.1.3.4. Mode_status (Multistate Input Object Type)	19
7.1.3.5. Mode_command (Multistate Output Object Type)	20
7.1.3.6. Setpoint_status (Analog Input Object Type)	21
7.1.3.7. Setpoint_command (Analog Output Object Type)	22
7.1.3.8. FanSpeed_status (Multistate Input Object Type)	23
7.1.3.9. FanSpeed_command (Multistate Output Object Type)	24
7.1.3.10. AirDirectionUD_status (Multistate Input Object Type)	25
7.1.3.11. AirDirectionUD_command (Multistate Output Object Type)	26
7.1.3.12. RoomTemperature_status (Analog Input Object Type)	27
7.1.3.13. RoomTemperature_command (Analog Output Object Type)	28
7.1.3.14. ErrorCode (Analog Input Object Type)	29
7.1.3.15. ErrorCodeM (Multistate Input Object Type)	30
7.1.3.16. ErrorActive (Binary Input Object Type)	31
7.1.3.17. ErrorAddress (Analog Input Object Type)	32
7.1.3.18. ErrorReset (Binary Output Object Type)	33
7.1.3.19. OnTimeCounter (Analog Value Object Type)	34
7.1.3.20. Occupancy (Multistate Value Object Type)	35
7.1.3.21. OccupiedCoolSetPoint (Analog Value Object Type)	36

7.1.3.22. OccupiedHeatSetPoint (Analog Value Object Type)	37
7.1.3.23. UnoccupiedCoolSetPoint (Analog Value Object Type)	38
7.1.3.24. UnoccupiedHeatSetPoint (Analog Value Object Type)	39
7.1.3.25. OccupancyContinuousCheck (Binary Value Object Type)	40
7.1.3.26. UnoccupiedDeadbandAction (Binary Value Object Type)	41
7.1.3.27. SerialNumber (Analog Input Object Type)	42
7.1.3.28. LockRemoteControl (Binary Value Object Type)	43
7.1.3.29. UserSetPoint_status (Analog Input Object Type)	44
7.1.3.30. VirtualTemperatureActive (Binary Input Object Type)	45
7.1.3.31. FilterSignAddress (Analog Input Object Type)switches	46
7.1.3.32. DIP_SW_S1_status (Analog Input Object Type)	47
7.1.3.33. DIP_SW_S2_status (Analog Input Object Type)	48
7.1.3.34. FilterSign (Binary Input Object Type)	49
7.1.3.35. FilterReset (Binary Output Object Type)	50
7.1.3.36. ResetBehaviour (Multistate Value Object Type)	51
7.2. Occupancy	51
7.3. Considerations on BACnet Temperature Objects	54
8. Modbus Application Specifications	55
8.1. Implemented Modbus Functions	55
8.1.1. Modbus Physical Layer	55
8.1.2. Modbus Registers	55
8.2. Considerations on Modbus Temperature Registers	61
9. Virtual Temperature	62
10. Error Codes	64
10.1. Gateway Codes	64
10.2. AC System Codes	64

1. Description, Compatible AC systems, and Order Codes

BACnet MS/TP and Modbus RTU Server Gateway for Hitachi Air Conditioners.

Compatible with commercial and VRV air conditioning systems commercialized by Hitachi.

Use the compatibility tool to get a complete list of compatible AC units: <https://compatibility.intesis.com/#>



IMPORTANT

This gateway is compatible with Modbus from firmware version 1.0.2.0 onwards. If you need to update your gateway, please contact the support department at <https://support.hms-networks.com/hc/en-us>.

ORDER CODE	LEGACY ORDER CODE
IN485HIT001R000	INMBSHIT001R000

2. General Information

2.1. Intended Use of the User Manual

This manual contains the main features of this Intesis gateway and the instructions for its appropriate installation, configuration, and operation.

The contents of this manual should be brought to the attention of any person who installs, configures, or operates this gateway or any associated equipment.

Keep this manual for future reference during the installation, configuration, and operation.

2.2. General Safety Information



IMPORTANT

Follow these instructions carefully. Improper work may seriously harm your health and damage the gateway and/or any other equipment connected to it.

Only technical personnel, following these instructions and the country legislation for installing electrical equipment, can install and manipulate this gateway.

Install this gateway indoors, in a restricted access location, avoiding exposure to direct solar radiation, water, high relative humidity, or dust.

All wires (for communication and power supply, if needed) must only be connected to networks with indoor wiring. All communication ports are considered for indoor use and must only be connected to SELV circuits.

Disconnect all systems from power before manipulating and connecting them to the gateway.

Use SELV-rated NEC class 2 or limited power source (LPS) power supply.

Supply always a correct voltage to power the gateway. See [Technical Specifications \(page 12\)](#).

Respect the expected polarity of power and communication cables when connecting them to the gateway.

2.3. Admonition Messages and Symbols



DANGER

Instructions that must be followed to avoid an imminently hazardous situation that, if not avoided, will result in death or severe injury.



WARNING

Instructions that must be followed to avoid a potentially hazardous situation that, if not avoided, could result in death or severe injury.



CAUTION

Instruction that must be followed to avoid a potentially hazardous situation that, if not avoided, could result in minor or moderate injury.



IMPORTANT

Instruction that must be followed to avoid a risk of reduced functionality and/or damage to the equipment or to avoid a network security risk.



NOTE

Additional information which may facilitate installation and/or operation.



TIP

Helpful advice and suggestions.



NOTICE

Remarkable Information.

3. Quickstart Guide for the IN485HIT001R000 Gateway



IMPORTANT

Disconnect all systems from power before connecting them to the gateway.

1. Mount the gateway in the desired installation site. This gateway can be mounted over a DIN rail, a wall, or inside the indoor unit (in some indoor unit models only).



NOTE

DIN rail mounting inside a grounded cabinet or metal enclosure is recommended.

2. Connect the gateway to the BACnet/Modbus network via its EIA-485 port.
3. Connect the gateway to the wired remote controller bus (AB). See details in [Connection Procedure \(page 7\)](#).
4. Configure the gateway using the built-in DIP switches. See details in [DIP Switches \(page 9\)](#).



NOTE

Use the SW1 DIP switch's position 5 to set the gateway as a BACnet or Modbus server device:

- BACnet MS/TP: Position 5 is off (down). This is the default setting.
- Modbus RTU: Position 5 is on (up).

5. Check the communication performance between the BACnet/Modbus bus and the AC system through the gateway's LED indicators. See details in [LED Indicators \(page 11\)](#).
6. The Intesis gateway is ready to be used in your system.

4. Overview



NOTE

You can set this IN485HIT001R000 gateway as a BACnet MS/TP or a Modbus RTU server device using the DIP switch block SW1 (position 5). See [DIP Switches \(page 9\)](#).

Figure 1. Integration of Hitachi AC units into a BACnet installation using the Intesis IN485HIT001R000 gateway

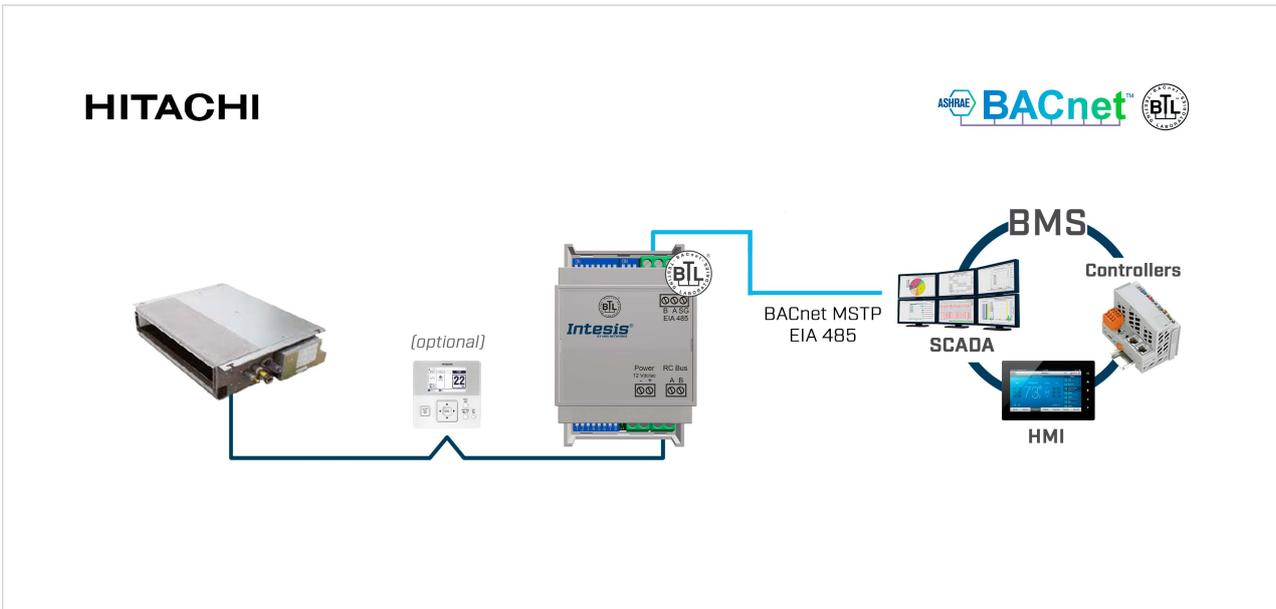
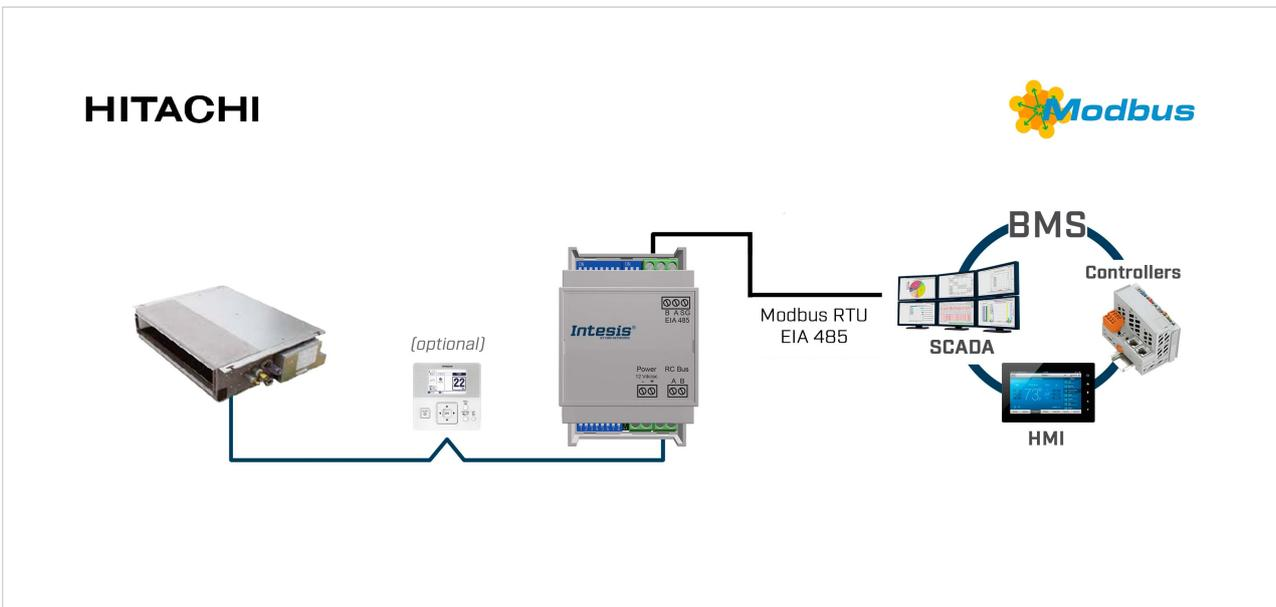

Figure 2. Integration of Hitachi AC units into a Modbus installation using the Intesis IN485HIT001R000 gateway



NOTE

This document assumes that the user is familiar with BACnet, Modbus, and Hitachi technologies and their technical terms.

4.1. Inside the Package

Items included:

- Intesis IN485HIT001R000 gateway
- Installation sheet

4.2. Main Features

- BTL seal ensures full interoperability with BACnet devices.
- Supports BACnet MS/TP and Modbus RTU.
- Configuration with onboard DIP switches.
- Quick and easy installation: Set the DIP switches, plug, and play.
- External power supply not required.
- Simultaneous control of the AC unit by the IR remote controller and by BACnet MS/TP.
- Reduced dimensions: 93 x 53 x 58 mm.
- Mountable on DIN rail, wall, or even inside the indoor unit in some models of AC.
- Significant reduction of the HVAC system energy consumption.
- Three-year warranty.

4.3. Gateway Capacity

This Intesis gateway can integrate one or more Hitachi AC units and their associated elements.

Element	Max
Number of indoor units that the gateway can control	1 (see note)
Number of Hitachi AC signals available as BACnet objects in the gateway	38
Number of AC signals available as Modbus registers	66



NOTE

You can connect several AC units to the gateway, but they will perform as one. This means you cannot send different commands to different units.

4.4. General Functionality

With this Intesis IN485HIT001R000 gateway, you can easily integrate Hitachi commercial and VRV air conditioning systems into an installation based on BACnet MS/TP or Modbus RTU. To do so, the gateway acts as a server device of the installation itself, accessing all signals from the AC indoor unit.

The gateway is continuously polling the AC unit, storing in its memory the current status of every signal you want to track and serving this data to the installation when requested. The gateway also sends the requested commands to the indoor unit.

If the AC unit has a wired remote controller (RC), you can:

- Set the wired RC as header and the gateway as follower.
- Set the wired RC as follower and the gateway as header.



NOTE

- You can configure this behavior via the DIP switch SW1. See [DIP Switches \(page 9\)](#).
- For more information on the wired RC connection, see [Connection Procedure \(page 7\)](#).

5. Hardware

5.1. Connection Procedure



CAUTION

Disconnect all systems from power before connecting them to the gateway.



IMPORTANT

Keep communication cables away from power and ground wires.

Figure 3. Wiring diagram

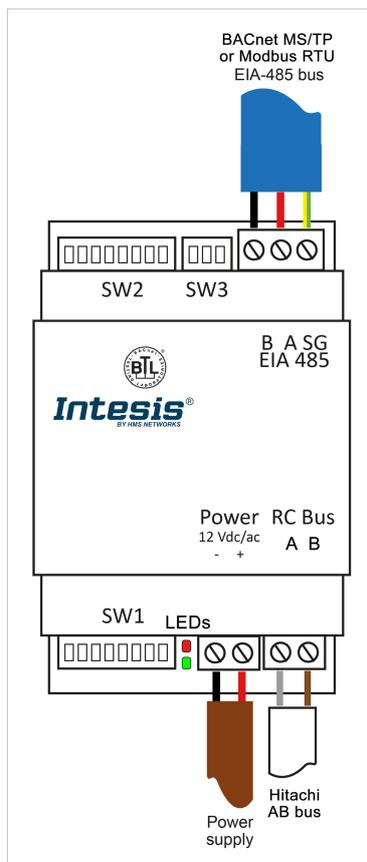

Connection to the wired remote controller bus

1. Mount the Intesis gateway in the desired installation site.
2. Connect the gateway at any point of the AB bus.



NOTE

- The AB bus is a two-wire bus that connects the AC indoor unit and the wired remote controller.
- This connection has no specific polarity.

If the AC unit has a wired remote controller (RC), you can:

- Set the wired RC as header and the gateway as follower.
- Set the wired RC as follower and the gateway as header.



NOTE

You can configure this behavior via the DIP switch SW1. See [DIP Switches \(page 9\)](#).



IMPORTANT

Although it is not mandatory, we recommend connecting a wired remote controller in the RC bus since it may be necessary to establish proper communication with some indoor units.

Connection to the BACnet MS/TP or Modbus RTU bus

3. Connect the BACnet MS/TP or Modbus RTU bus to the EIA-485 port of the gateway.



IMPORTANT

Observe polarity: B-, A+, and SG for signal ground.



IMPORTANT

- EIA-485 bus doesn't allow loop or star topologies.
- Maximum length for the EIA-485 bus is 1200 meters.

4. Reconnect all systems to power.

5.2. Connection to an External Power Supply



IMPORTANT

In most cases, this gateway is powered by the remote controller bus itself, and there is no need to connect an external power supply. However, depending on the number and type of remote controllers installed, the bus could not supply the needed power.



TIP

Some signs indicating there is not enough power in the bus may include, for example, a malfunction of the remote controllers' displays or performance.

If that's the case, connect a 12 VDC/AC SELV-rated NEC class 2 or Limited Power Source (LPS) power supply in the gateway's Power connector.



IMPORTANT

Respect polarity.

Figure 4. Power connector

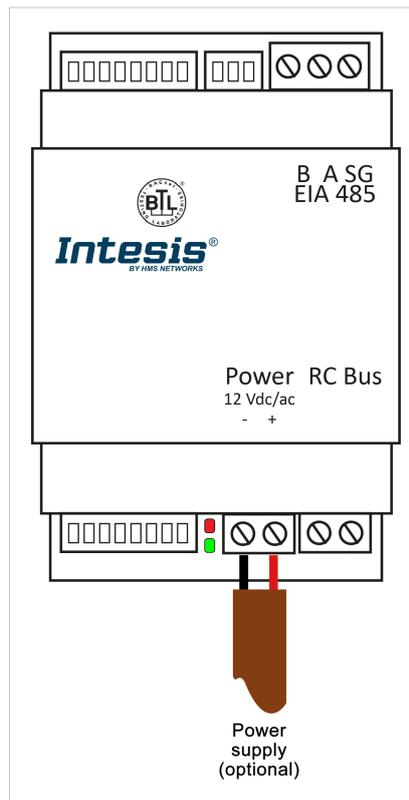

5.3. DIP Switches

The gateway includes three DIP switches: SW1 (8 switches) at the bottom; SW2 (8 switches) and SW3 (3 switches) at the top.

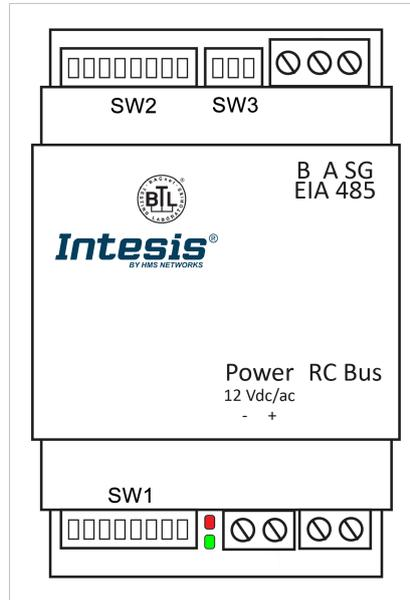

Table 1. **SW1** (P1, P5): Gateway configuration; (P6 to P8): BACnet MS/TP or Modbus RTU baudrate

Binary value b0 .. b7	Position								Description	
	1	2	3	4	5	6	7	8	BACnet	Modbus
0XXXXXXXX	↓	X	X	X	X	X	X	X	Follower in RC bus (default)	Follower in RC bus (default)
1XXXXXXXX	↑	X	X	X	X	X	X	X	Header in RC bus	Header in RC bus
01XXXXXXXX	↓	↑	X	X	X	X	X	X	-	-
11XXXXXXXX	↑	↑	X	X	X	X	X	X	-	-
XXXX0XXX	X	X	X	X	↓	X	X	X	BACnet MS/TP in 485 port enabled (default)	Modbus RTU in 485 port disabled (default)
XXXX1XXX	X	X	X	X	↑	X	X	X	BACnet MS/TP in 485 port disabled	Modbus RTU in 485 port enabled
XXXXX000	X	X	X	X	X	↓	↓	↓	Autobaudrate (default)	2400 bps
XXXXX100	X	X	X	X	X	↑	↓	↓	9600 bps	4800 bps
XXXXX010	X	X	X	X	X	↓	↑	↓	19200 bps	9600 bps
XXXXX110	X	X	X	X	X	↑	↑	↓	38400 bps	19200 bps
XXXXX001	X	X	X	X	X	↓	↓	↑	57600 bps	38400 bps
XXXXX101	X	X	X	X	X	↑	↓	↑	76800 bps	57600 bps
XXXXX011	X	X	X	X	X	↓	↑	↑	115200 bps	76800 bps
XXXXX111	X	X	X	X	X	↑	↑	↑	Autobaudrate	115200 bps



NOTE

If **Autobaudrate** is selected, the gateway will scan the network to find any other BACnet MS/TP device and will match its baudrate. Once detected, the baudrate will only be modified after a reset/reboot of the gateway.

Table 2. **SW2 (BACnet MS/TP)** (P1 to P7): BACnet MS/TP MAC address; (P8): Temperature unit (°C/°F)

Binary value b0 .. b7	Position								BACnet address	Description
	1	2	3	4	5	6	7	8		
0000000X	↓	↓	↓	↓	↓	↓	↓	X	0	-
1000000X	↑	↓	↓	↓	↓	↓	↓	X	1	-
0100000X	↓	↑	↓	↓	↓	↓	↓	X	2	-
1100000X	↑	↑	↓	↓	↓	↓	↓	X	3	-
...									...	-
1011111X	↑	↓	↑	↑	↑	↑	↑	X	125	-
0111111X	↓	↑	↑	↑	↑	↑	↑	X	126	-
1111111X	↑	↑	↑	↑	↑	↑	↑	X	127	-
XXXXXXX0	X	X	X	X	X	X	X	↓	-	Temperature in Celsius (default)
XXXXXXX1	X	X	X	X	X	X	X	↑	-	Temperature in Fahrenheit

Table 3. **SW2 (Modbus RTU)** (P1 to P6): Modbus server address; (P7): Degree decimals setting (P8): Temperature unit (°C/°F)

Binary value b0 .. b7	Position								Modbus address	Description
	1	2	3	4	5	6	7	8		
100000XX	↑	↓	↓	↓	↓	↓	X	X	1	-
010000XX	↓	↑	↓	↓	↓	↓	X	X	2	-
110000XX	↑	↑	↓	↓	↓	↓	X	X	3	-
...									...	-
101111XX	↑	↓	↑	↑	↑	↑	X	X	61	-
011111XX	↓	↑	↑	↑	↑	↑	X	X	62	-
111111XX	↑	↑	↑	↑	↑	↑	X	X	63	-
XXXXXX0X	X	X	X	X	X	X	↓	X	-	Temperature in degrees x1 (default)
XXXXXX1X	X	X	X	X	X	X	↑	X	-	Temperature in degrees x10. Example: 19.2°=192
XXXXXXX0	X	X	X	X	X	X	X	↓	-	Temperature in Celsius (default)
XXXXXXX1	X	X	X	X	X	X	X	↑	-	Temperature in Fahrenheit

Table 4. **SW3** (P1 to P3): BACnet/Modbus polarization and termination resistor

Binary value b0 .. b2	Position			Description
	1	2	3	
0 X X	↓	X	X	EIA-485 bus without termination resistor. The gateway is not at one end of the EIA-485 bus (default value)
1 X X	↑	X	X	120 Ω termination resistor active. The gateway is at one end of the EIA-485 bus
X 0 0	X	↓	↓	No bus polarization (default value)
X 1 1	X	↑	↑	Bus polarization active

**IMPORTANT**

The DIP switch configuration will only take effect after rebooting the gateway.

5.4. LED Indicators

There are two LEDs at the lower side of the gateway, between the DIP switch block SW1 and the **Power** connector.

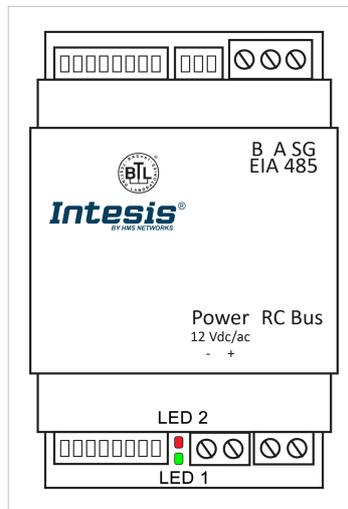

When powering the gateway up, both LEDs blink once and then turn off. After that, LEDs will behave as described in the table below:

LED	Status	Description
When the gateway is set for BACnet MS/TP		
L1 Green	ON	EIA-485 bus link performed
	Flickering	Activity on the EIA/485 bus
	OFF	EIA-485 bus link not performed
L2 Red	ON	AC communication error
	Blinking	AC unit error
	Flashing	AC communication OK
When the gateway is set for Modbus RTU		
L1 Green	Blinking	Communication error Any error in the AC unit
	Flashing	Normal operation
L1 Green + L2 Red	Pulse	Gateway startup



LED PATTERNS

- **ON:** 100% on
- **Flickering:** irregular cycle (90% on - 10% off approx)
- **Blinking:** 50% on - 50% off
- **Flashing:** 10% on - 90% off
- **OFF:** 100% off

5.5. Technical Specifications

Housing	Plastic, type PC (UL 94 V-0) Net dimensions (DxWxH): 93 x 53 x 58 mm / 3.7 x 2.1 x 2.3" Color: Light grey. RAL 7035
Weight	85 g (3 oz)
Terminal wiring	Per terminal: solid wires or stranded wires (twisted or with ferrule). Wire cross-section/gauge: One core: 0.2 to 2.5 mm ² (24 to 11 AWG) Two cores: 0.2 to 1.5mm ² (24 to 15 AWG) Three cores: Not permitted
External power supply (optional)	SELV-rated NEC class 2 or limited power source (LPS) power supply. 12 VDC/AC; 0.1 A
Mounting	Wall or DIN rail
BACnet MS/TP - Modbus RTU port	1 x EIA-485 pluggable terminal block (3 poles: B, A, and SG) with 120 Ω resistor termination and polarisation configurable by DIP switch
AC unit port	1 x RC bus pluggable terminal block (2 poles)
LED indicators	2 x Communication status
DIP switches	SW1: Gateway and baudrate configuration SW2: BACnet/Modbus address and temperature unit SW3: Bus polarization and termination
Operational and storage temperature	Celsius: Op: 0 to +70°C; St: -20 to 85°C Fahrenheit: 32 to 158°F; St: -4 to 185°F
Operational and storage humidity	5% to 95% RH non-condensing
Isolation Voltage	1500 VDC
Isolation resistance	1000 MΩ

5.6. Dimensions

Net dimensions (DxWxH):

Millimeters: 93 x 53 x 58 mm

Inches: 3.66 x 2.08 x 2.28"



IMPORTANT

Leave enough clear space to wire the gateway easily and for the subsequent manipulation of elements such as connectors, DIP switches, etc.

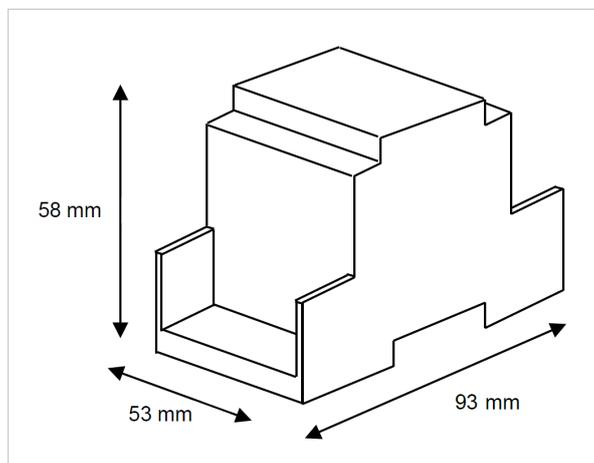

6. Restore the Factory Settings

To restore the gateway's factory settings, proceed as follows:

1. Set all switches from DIP switches SW1 and SW2 to the ON position.
2. Reboot the gateway:
 - a. Power it OFF.
 - b. Power it ON.



NOTE

To turn the gateway OFF, disconnect it from the AC unit and from the power supply, if there is one. To turn the gateway ON, reestablish those connections.

3. After the reboot, LEDs will blink with the SOS Morse sequence:
 - a. Three short blinks
 - b. Three longer blinks
 - c. Three short blinks
4. Set all switches from DIP switches SW1 and SW2 DIP to the OFF position before 30 seconds pass.¹

After this procedure, the LED will flash red, meaning that the gateway is already restored to the factory settings.

To continue working with the gateway, proceed as usual:

1. Set the DIP switches again depending on the desired configuration.
2. Reset the device:
 - a. Power it OFF.
 - b. Power it ON.



IMPORTANT

¹ If you take longer than 30 seconds, all LEDs will turn off, meaning that the procedure has failed. To retry it, begin the whole procedure again.

7. BACnet Application Specifications

The following sections provide the gateway's specifications when set as a BACnet MS/TP server device.

7.1. Objects

7.1.1. Supported Object Types

Object type	ID
Analog-Input	0
Analog-Output	1
Analog-Value	2
Binary-Input	3
Binary-Output	4
Binary-Value	5
Device	8
Multistate-Input	13
Multistate-Output	14
Multistate-Value	19

7.1.2. Member Objects

7.1.2.1. Type: Gateway

Object name	Description	Object type	Object instance
IN485HIT001R000	Hitachi commercial and VRF gateway	Device	246000 (default)

7.1.2.2. Type: Indoor Unit

Object name	Object type	Object instance
OnOff_status	BI	0
OnOff_command	BO	0
Mode_status	MI	0
Mode_command	MO	0
SetPoint_status	AI	0
Setpoint_command	AO	0
FanSpeed_status	MI	1
FanSpeed_command	MO	1
AirDirectionUD_status	MI	2
AirDirectionUD_command	MO	2
RoomTemperature_status	AI	1
RoomTemperature_command	AO	1
ErrorCode	AI	2
ErrorCodeM	MI	4
ErrorActive	BI	1
ErrorAddress	AI	2
ErrorReset	BO	5
OnTimeCounter	AV	0
Occupancy	MV	0

Object name	Object type	Object instance
OccupiedCoolSetpoint	AV	1
OccupiedHeatSetpoint	AV	2
UnoccupiedCoolSetpoint	AV	3
UnoccupiedHeatSetpoint	AV	4
OccupancyContinuousCheck	BV	0
UnoccupiedDeadBandAction	BV	1
SerialNumber	AI	11
LockRemoteControl	BV	2
UserSetPoint_status	AI	17
VirtualTempActive	BI	14
FilterSignAddress	AI	18
DIP_SW_S1_status	AI	9
DIP_SW_S2_status	AI	10
FilterSign	BI	6
FilterReset	BO	4
ResetBehavior	MV	4

7.1.3. Objects and Properties

7.1.3.1. Hitachi AC Gateway (Device Object Type)

Object_Identifier: The gateway can be identified in the BACnet network automatically or manually:

- **Automatic addressing (default):** This mode uses a base address of 146000 + the MAC address number selected in the DIP switch SW2.
- **Manual addressing:** The gateway switches to this mode when this property receives a value from the BACnet side.



IMPORTANT

During the manual addressing mode, the gateway will not consider the MAC address configured with the DIP switch SW2.



IMPORTANT

If the **Object_Identifier** is overwritten from the BACnet side, the DIP switch SW2 configuration will not be considered for the Device instance calculation until the gateway is reset to the factory settings. See [Restore the Factory Settings \(page 13\)](#).

Object_name: In the **Device Object**, is configurable writing directly on this property.

Description: In the **Device Object**, is configurable writing directly on the property. Max. length: 63 characters.

Property Identifier	Property Datatype	Value	ASHRAE	Gateway
Object_Identifier	BACnetObjectIdentifier	Device, 246000 (default value)	R	W
Object_Name	CharacterString	IN485HIT001R000	R	W
Object_Type	BACnetObjectType	DEVICE (8) (Device Object Type)	R	R
System_Status	BACnetDeviceStatus	OPERATIONAL (0)	R	R
Vendor_Name	CharacterString	HMS Industrial Networks SLU	R	R
Vendor_Identifier	Unsigned16	246	R	R
Model_Name	CharacterString	IN485HIT001R000	R	R
Firmware_Revision	CharacterString	1.0.0.0	R	R
Application_Software_Version	CharacterString	1.0.0.0	R	R

Property Identifier	Property Datatype	Value	ASHRAE	Gateway
Location	CharacterString	""	O	-
Description	CharacterString	RC interface Hitachi AC interface	O	W
Protocol_Version	Unsigned	1	R	R
Protocol_Revision	Unsigned	12	R	R
Protocol_Services_Supported	BACnetServiceSupported	-	R	R
Protocol_Object_Types_Supported	BACnetObjectTypes Supported	Refer to section Supported Object Types (page 14)	R	R
Object_List	BACnetArray[N] of BACnetObjectIdentifier	BACnetARRAY[N]	R	R
Structured_Object_List	BACnetArray[N] of BACnetObjectIdentifier	-	O	-
Max_APDU_Length_Accepted	Unsigned	480 for MS/TP	R	R
Segmentation_Supported	BACnetSegmentation	SEGMENTED-BOTH (0)	R	R
Max_Segments_accepted	Unsigned	16	O	R
VT_Classes_Supported	List of BACnetVTClass	-	O	-
Active_VT_Sessions	List of BACnetVTSession	-	O	-
Local_Date	Date	-	O	-
Local_Time	Time	-	O	-
UTC_Offset	INTEGER	-	O	-
Daylight_Savings_Status	BOOLEAN	-	O	-
APDU_Segment_Timeout	Unsigned	3000	R	R
APDU_Timeout	Unsigned	3000	R	R
Number_of_APDU_Retries	Unsigned	3	R	R
List_Of_Session_Keys	List of BACnetSessionKey	-	O	-
Time_Synchronization_Recipients	List of BACnetRecipient	-	O	-
Max_Master	Unsigned	32	R	W
Max_Info_Frames	Unsigned	1	O	R
Device_Address_Binding	List of BACnetAddressBinding	NULL (empty)	R	R
Database_Revision	Unsigned	0	R	R
Configuration_Files	BACnetArray[N] of BACnetObjectIdentifier	-	O	-
Last_Restore_Time	BACnetTimeStamp	-	O	-
Backup_Failure_Timeout	Unsigned16	-	O	-
Active_COV_Subscriptions	List of BACnetCOVSubscription	List of BACnetCOVSubscription	O	R
Slave_Proxy_Enable	BACnetArray[N] of BOOLEAN	-	O	-
Manual_Slave_Address_Binding	List of BACnetAddressBinding	-	O	-
Auto_Slave_Discovery	BACnetArray[N] of BOOLEAN	-	O	-
Slave_Address_Binding	BACnetAddressBinding	-	O	-
Last_Restart_Reason	BACnetRestartReason	-	O	-
Time_Of_Device_Restart	BACnetTimeStamp	-	O	-
Restart_Notification_Recipients	List of BACnetRecipient	-	O	-
UTC_Time_Synchronization_Recipients	List of BACnetRecipient	-	O	-
Time_Synchronization_Interval	Unsigned	-	O	-
Align_Intervals	BOOLEAN	-	O	-
Interval_Offset	Unsigned	-	O	-
Profile_Name	CharacterString	-	O	-

7.1.3.2. OnOff_status (Binary Input Object Type)

It indicates if the indoor unit is turned on or off.

Property Identifier	Property Datatype	Value	ASHRAE	Gateway
Object_Identifier	BACnetObjectIdentifier	(Binary Input, 0)	R	R
Object_Name	CharacterString	OnOff_status	R	R
Object_Type	BACnetObjectType	BINARY_INPUT (3)	R	R
Present_Value	BACnetBinaryPV	INACTIVE (0) / ACTIVE (1)	R	R
Description	CharacterString	-	O	-
Device_Type	CharacterString	-	O	-
Status_Flags	BACnetStatusFlags	{FALSE, FALSE/TRUE, FALSE, FALSE}	R	R
Event_State	BACnetEventState	STATE_NORMAL (0)	R	R
Reliability	BACnetReliability	NO_FAULT_DETECTED (0), UNRELIABLE_OTHER (7)	O	R
Out_Of_Service	BOOLEAN	FALSE	R	R
Polarity	BACnetPolarity	NORMAL (0)	R	R
Inactive_Text	CharacterString	Off	O	R
Active_Text	CharacterString	On	O	R
Change_Of_State_Time	BACnetDatetime	-	O	-
Change_Of_State_Count	Unsigned	-	O	-
Time_Of_State_Count_Reset	BACnetDatetime	-	O	-
Elapsed_Active_Time	Unsigned	-	O	-
Time_Of_Active_Time_Reset	BACnetDatetime	-	O	-
Time_Delay	Unsigned	-	O	-
Notification_Class	Unsigned	-	O	-
Alarm_Value	BACnetBinaryPV	-	O	-
Event_Enable	BACnetEventTransitionBits	-	O	-
Acked_Transitions	BACnetEventTransitionBits	-	O	-
Notify_Type	BACnetNotifyType	-	O	-
Event_Time_Stamps	BACnetArray[N] of BACnetTimeStamp	-	O	-
Profile_Name	CharacterString	-	O	-

7.1.3.3. OnOff_command (Binary Output Object Type)

It turns the indoor unit on or off.

Property Identifier	Property Datatype	Value	ASHRAE	Gateway
Object_Identifier	BACnetObjectIdentifier	(Binary Output, 0)	R	R
Object_Name	CharacterString	OnOff_command	R	R
Object_Type	BACnetObjectType	BINARY_OUTPUT (4)	R	R
Present_Value	BACnetBinaryPV	INACTIVE (0) / ACTIVE (1)	R	W
Description	CharacterString	-	O	-
Device_Type	CharacterString	-	O	-
Status_Flags	BACnetStatusFlags	{FALSE, FALSE, FALSE, FALSE}	R	R
Event_State	BACnetEventState	STATE_NORMAL (0)	R	R
Reliability	BACnetReliability	NO_FAULT_DETECTED (0)	O	R
Out_Of_Service	BOOLEAN	FALSE	R	R
Polarity	BACnetPolarity	NORMAL (0)	R	R
Inactive_Text	CharacterString	Off	O	R
Active_Text	CharacterString	On	O	R
Change_Of_State_Time	BACnetDatetime	-	O	-
Change_Of_State_Count	Unsigned	-	O	-
Time_Of_State_Count_Reset	BACnetDatetime	-	O	-
Elapsed_Active_Time	Unsigned	-	O	-
Time_Of_Active_Time_Reset	BACnetDatetime	-	O	-
Minimum_Off_Time	Unsigned32	-	O	-
Minimum_On_Time	Unsigned32	-	O	-
Priority_Array	BACnetPriorityArray	BACnetPriorityArray	R	R
Relinquish_Default	BACnetBinaryPV	INACTIVE (0)	R	R
Time Delay	Unsigned	-	O	-
Notification_Class	Unsigned	-	O	-
Feedback_Value	BACnetBinaryPV	-	O	-
Event_Enable	BACnetEventTransitionBits	-	O	-
Acked_Transitions	BACnetEventTransitionBits	-	O	-
Notify_Type	BACnetNotifyType	-	O	-
Event_Time_Stamps	BACnetArray[N] of BACnetTimeStamp	-	O	-
Profile_Name	CharacterString	-	O	-

7.1.3.4. Mode_status (Multistate Input Object Type)

It indicates the indoor unit's current mode.

Property Identifier	Property Datatype	Value	ASHRAE	Gateway
Object_Identifier	BACnetObjectIdentifier	(Multistate Input, 0)	R	R
Object_Name	CharacterString	Mode_status	R	R
Object_Type	BACnetObjectType	MULTISTATE_INPUT (13)	R	R
Present_Value	Unsigned	1 .. 5	R	R
Description	CharacterString	-	O	-
Device_Type	CharacterString	-	O	-
Status_Flags	BACnetStatusFlags	{FALSE, FALSE/TRUE, FALSE, FALSE}	R	R
Event_State	BACnetEventState	STATE_NORMAL (0)	R	R
Reliability	BACnetReliability	NO_FAULT_DETECTED (0), UNRELIABLE_OTHER(7)	O	R
Out_Of_Service	BOOLEAN	FALSE	R	R
Number_Of_States	Unsigned	5	R	R
State_Text	BACnetArray[N] of CharacterString	Check the Mode status table below.	O	R
Time_Delay	Unsigned	-	O	-
Notification_Class	Unsigned	-	O	-
Alarm_Values	List of Unsigned	-	O	-
Fault_Values	List of Unsigned	-	O	-
Event_Enable	BACnetEventTransitionBits	-	O	-
Acked_Transitions	BACnetEventTransitionBits	-	O	-
Notify_Type	BACnetNotifyType	-	O	-
Event_Time_Stamps	BACnetArray[N] of BACnetTimeStamp	-	O	-
Profile_Name	CharacterString	-	O	-

Table 5. Mode status

Present_Value	State_Text
1	Heat
2	Cool
3	Fan
4	Dry
5	Auto

7.1.3.5. Mode_command (Multistate Output Object Type)

It sets the AC indoor unit's mode.

Property Identifier	Property Datatype	Value	ASHRAE	Gateway
Object_Identifier	BACnetObjectIdentifier	(Multistate Output,0)	R	R
Object_Name	CharacterString	Mode_command	R	R
Object_Type	BACnetObjectType	MULTISTATE_OUTPUT (14)	R	R
Present_Value	Unsigned	1 .. 5	R	W
Description	CharacterString	-	O	-
Device_Type	CharacterString	-	O	-
Status_Flags	BACnetStatusFlags	{FALSE, FALSE, FALSE, FALSE}	R	R
Event_State	BACnetEventState	STATE_NORMAL (0)	R	R
Reliability	BACnetReliability	NO_FAULT_DETECTED (0)	O	R
Out_Of_Service	BOOLEAN	FALSE	R	R
Number_Of_States	Unsigned	5	R	R
State_Text	BACnetArray[N] of CharacterString	Check the Mode command table below	O	R
Priority_Array	BACnetPriorityArray	BACnetPriorityArray	R	R
Relinquish_Default	Unsigned	1	R	R
Time_Delay	Unsigned	-	O	-
Notification_Class	Unsigned	-	O	-
Feedback_Value	Unsigned	-	O	-
Event_Enable	BACnetEventTransitionBits	-	O	-
Acked_Transitions	BACnetEventTransitionBits	-	O	-
Notify_Type	BACnetNotifyType	-	O	-
Event_Time_Stamps	BACnetArray[N] of BACnetTimeStamp	-	O	-
Profile_Name	CharacterString	-	O	-

Table 6. Mode command

Present_Value	State_Text
1	Heat
2	Cool
3	Fan
4	Dry
5	Auto

7.1.3.6. Setpoint_status (Analog Input Object Type)

It indicates the current temperature setpoint for the indoor unit.

Property Identifier	Property Datatype	Value	ASHRAE	Gateway
Object_Identifier	BACnetObjectIdentifier	(Analog Input, 0)	R	R
Object_Name	CharacterString	SetPoint_status	R	R
Object_Type	BACnetObjectType	ANALOG_INPUT (0)	R	R
Present_Value	REAL	16 .. 32°C / 61 .. 90°F	R	R
Description	CharacterString	-	O	-
Device_Type	CharacterString	-	O	-
Status_Flags	BACnetStatusFlags	{FALSE, FALSE/TRUE, FALSE, FALSE}	R	R
Event_State	BACnetEventState	STATE_NORMAL (0)	R	R
Reliability	BACnetReliability	NO_FAULT_DETECTED (0), UNRELIABLE_OTHER (7)	O	R
Out_Of_Service	BOOLEAN	FALSE	R	R
Update_Interval	Unsigned	-	O	-
Units	BACnetEngineeringUnits	Celsius degrees (62) Fahrenheit degrees (64)	R	R
Min_Pres_Value	REAL	16°C / 61°F	O	R
Max_Pres_Value	REAL	32°C / 90°F	O	R
Resolution	REAL	-	O	-
COV_Increment	REAL	0	O	W
Time_Delay	Unsigned	-	O	-
Notification_Class	Unsigned	-	O	-
High_Limit	REAL	-	O	-
Low_Limit	REAL	-	O	-
Deadband	REAL	-	O	-
Limit_Enable	BACnetLimitEnable	-	O	-
Event_Enable	BACnetEventTransitionBits	-	O	-
Acked_Transitions	BACnetEventTransitionBits	-	O	-
Notify_Type	BACnetNotifyType	-	O	-
Event_Time_Stamps	BACnetArray[N] of BACnetTimeStamp	-	O	-
Profile_Name	CharacterString	-	O	-



NOTE

You can set the temperature scale in Celsius or Fahrenheit via the DIP switches. More information in [DIP Switches \(page 9\)](#).

7.1.3.7. Setpoint_command (Analog Output Object Type)

It sets the desired temperature for the indoor unit.

Property Identifier	Property Datatype	Value	ASHRAE	Gateway
Object_Identifier	BACnetObjectIdentifier	(Analog Output, 0)	R	R
Object_Name	CharacterString	SetPoint_command	R	R
Object_Type	BACnetObjectType	ANALOG_OUTPUT (1)	R	R
Present_Value	REAL	16 .. 32°C / 61 .. 90°F	W	W
Status_Flags	BACnetStatusFlags	{FALSE, FALSE, FALSE, FALSE}	R	R
Event_State	BACnetEventState	STATE_NORMAL (0)	R	R
Reliability	BACnetReliability	NO_FAULT_DETECTED (0)	O	R
Out_Of_Service	BOOLEAN	FALSE	R	R
Update_Interval	Unsigned	-	O	-
Units	BACnetEngineeringUnits	Celsius degrees (62) Fahrenheit degrees (64)	R	R
Min_Pres_Value	REAL	16°C / 61°F	O	R
Max_Pres_Value	REAL	32°C / 90°F	O	R
Resolution	R	-	O	-
COV_Increment	REAL	0	O	W
Priority_Array	BACnetPriorityArray	BACnetPriorityArray	R	R
Relinquish_Default	Unsigned	22	R	R
Time_Delay	Unsigned	-	O	-
Notification_Class	Unsigned	-	O	-
High_Limit	REAL	-	O	-
Low_Limit	REAL	-	O	-
Deadband	REAL	-	O	-
Limit_Enable	BACnetLimitEnable	-	O	-
Event_Enable	BACnetEventTransitionBits	-	O	-
Acked_Transitions	BACnetEventTransitionBits	-	O	-
Notify_Type	BACnetNotifyType	-	O	-
Event_Time_Stamps	BACnetArray[N] of BACnetTimeStamp	-	O	-
Profile_Name	CharacterString	-	O	-



NOTE

You can set the temperature scale in Celsius or Fahrenheit scale via DIP switches. More information in [DIP Switches \(page 9\)](#).

7.1.3.8. FanSpeed_status (Multistate Input Object Type)

It indicates the indoor unit's fan speed.

Property Identifier	Property Datatype	Value	ASHRAE	Gateway
Object_Identifier	BACnetObjectIdentifier	(Multistate Input, 1)	R	R
Object_Name	CharacterString	FanSpeed_status	R	R
Object_Type	BACnetObjectType	MULTISTATE_INPUT (13)	R	R
Present_Value	Unsigned	1 .. 5	R	R
Description	CharacterString	-	O	-
Device_Type	CharacterString	-	O	-
Status_Flags	BACnetStatusFlags	{FALSE, FALSE/TRUE, FALSE, FALSE}	R	R
Event_State	BACnetEventState	STATE_NORMAL (0)	R	R
Reliability	BACnetReliability	NO_FAULT_DETECTED (0), UNRELIABLE_OTHER (7)	O	R
Out_Of_Service	BOOLEAN	FALSE/TRUE	R	R
Number_Of_States	Unsigned	5	R	R
State_Text	BACnetArray[N] of CharacterString	Check the Fan speed status table below.	O	R
Time_Delay	Unsigned	-	O	-
Notification_Class	Unsigned	-	O	-
Alarm_Values	List of Unsigned	-	O	-
Fault_Values	List of Unsigned	-	O	-
Event_Enable	BACnetEventTransitionBits	-	O	-
Acked_Transitions	BACnetEventTransitionBits	-	O	-
Notify_Type	BACnetNotifyType	-	O	-
Event_Time_Stamps	BACnetArray[N] of BACnetTimeStamp	-	O	-
Profile_Name	CharacterString	-	O	-

Table 7. Fan speed status

Present_Value	State_Text
1	Auto
2	Fan Speed 1
3	Fan Speed 2
4	Fan Speed 3
5	Fan Speed 4

7.1.3.9. FanSpeed_command (Multistate Output Object Type)

It sets the indoor unit's fan speed.

Property Identifier	Property Datatype	Value	ASHRAE	Gateway
Object_Identifier	BACnetObjectIdentifier	(Multistate Output, 1)	R	R
Object_Name	CharacterString	FanSpeed_command	R	R
Object_Type	BACnetObjectType	MULTISTATE_OUTPUT (14)	R	R
Present_Value	Unsigned	1 .. 5	R	W
Description	CharacterString	-	O	-
Device_Type	CharacterString	-	O	-
Status_Flags	BACnetStatusFlags	{FALSE, FALSE, FALSE, FALSE}	R	R
Event_State	BACnetEventState	STATE_NORMAL (0)	R	R
Reliability	BACnetReliability	NO_FAULT_DETECTED (0)	O	R
Out_Of_Service	BOOLEAN	FALSE	R	R
Number_Of_States	Unsigned	5	R	R
State_Text	BACnetArray[N] of CharacterString	Check the Fan speed command table below	O	R
Priority_Array	BACnetPriorityArray	BACnetPriorityArray	R	R
Relinquish_Default	Unsigned	1	R	R
Time_Delay	Unsigned	-	O	-
Notification_Class	Unsigned	-	O	-
Feedback_Value	Unsigned	-	O	-
Event_Enable	BACnetEventTransitionBits	-	O	-
Acked_Transitions	BACnetEventTransitionBits	-	O	-
Notify_Type	BACnetNotifyType	-	O	-
Event_Time_Stamps	BACnetArray[N] of BACnetTimeStamp	-	O	-
Profile_Name	CharacterString	-	O	-

Table 8. Fan speed command

Present_Value	State_Text
1	Auto
2	Fan Speed 1
3	Fan Speed 2
4	Fan Speed 3
5	Fan Speed 4

7.1.3.10. AirDirectionUD_status (Multistate Input Object Type)

It indicates the indoor unit's vertical air direction (up-down) status.

Property Identifier	Property Datatype	Value	ASHRAE	Gateway
Object_Identifier	BACnetObjectIdentifier	(Multistate Input, 2)	R	R
Object_Name	CharacterString	AirDirectionUD_status	R	R
Object_Type	BACnetObjectType	MULTISTATE_INPUT(13)	R	R
Present_Value	Unsigned	1 .. 8	R	R
Description	CharacterString	-	O	-
Device_Type	CharacterString	-	O	-
Status_Flags	BACnetStatusFlags	{FALSE, FALSE/TRUE, FALSE, FALSE}	R	R
Event_State	BACnetEventState	STATE_NORMAL (0)	R	R
Reliability	BACnetReliability	NO_FAULT_DETECTED (0), UNRELIABLE_OTHER (7)	O	R
Out_Of_Service	BOOLEAN	FALSE/TRUE	R	R
Number_Of_States	Unsigned	8	R	R
State_Text	BACnetArray[N] of CharacterString	Check the Air direction status table below.	O	R
Time_Delay	Unsigned	-	O	-
Notification_Class	Unsigned	-	O	-
Alarm_Values	List of Unsigned	-	O	-
Fault_Values	List of Unsigned	-	O	-
Event_Enable	BACnetEventTransitionBits	-	O	-
Acked_Transitions	BACnetEventTransitionBits	-	O	-
Notify_Type	BACnetNotifyType	-	O	-
Event_Time_Stamps	BACnetArray[N] of BACnetTimeStamp	-	O	-
Profile_Name	CharacterString	-	O	-

Table 9. Air direction up-down status

Present_Value	State_Text
1	POS1
2	POS2
3	POS3
4	POS4
5	POS5
6	POS6
7	POS7
8	SWING

7.1.3.11. AirDirectionUD_command (Multistate Output Object Type)

It sets the indoor unit's vertical air direction (up-down).

Property Identifier	Property Datatype	Value	ASHRAE	Gateway
Object_Identifier	BACnetObjectIdentifier	(Multistate Output, 2)	R	R
Object_Name	CharacterString	AirDirectionUD_command	R	R
Object_Type	BACnetObjectType	MULTISTATE_OUTPUT (14)	R	R
Present_Value	Unsigned	1 .. 8	R	W
Description	CharacterString	-	O	-
Device_Type	CharacterString	-	O	-
Status_Flags	BACnetStatusFlags	{FALSE, FALSE, FALSE, FALSE}	R	R
Event_State	BACnetEventState	STATE_NORMAL (0)	R	R
Reliability	BACnetReliability	NO_FAULT_DETECTED (0)	O	R
Out_Of_Service	BOOLEAN	FALSE	R	R
Number_Of_States	Unsigned	8	R	R
State_Text	BACnetArray[N] of CharacterString	Check the Air direction command table below	O	R
Priority_Array	BACnetPriorityArray	-	R	R
Relinquish_Default	Unsigned	-	R	R
Time_Delay	Unsigned	-	O	-
Notification_Class	Unsigned	-	O	-
Feedback_Value	Unsigned	-	O	-
Event_Enable	BACnetEventTransitionBits	-	O	-
Acked_Transitions	BACnetEventTransitionBits	-	O	-
Notify_Type	BACnetNotifyType	-	O	-
Event_Time_Stamps	BACnetArray[N] of BACnetTimeStamp	-	O	-
Profile_Name	CharacterString	-	O	-

Table 10. Air direction up-down command

Present_Value	State_Text
1	POS1
2	POS2
3	POS3
4	POS4
5	POS5
6	POS6
7	POS7
8	SWING

7.1.3.12. RoomTemperature_status (Analog Input Object Type)

It indicates the room temperature perceived by the AC indoor unit sensor.

Property Identifier	Property Datatype	Value	ASHRAE	Gateway
Object_Identifier	BACnetObjectIdentifier	(Analog Input, 1)	R	R
Object_Name	CharacterString	RoomTemperature_status	R	R
Object_Type	BACnetObjectType	ANALOG_INPUT (0)	R	R
Present_Value	REAL	-10 .. 50°C / 14 .. 122°F	R	R
Description	CharacterString	-	O	-
Device_Type	CharacterString	-	O	-
Status_Flags	BACnetStatusFlags	{FALSE, FALSE/TRUE, FALSE, FALSE}	R	R
Event_State	BACnetEventState	STATE_NORMAL (0)	R	R
Reliability	BACnetReliability	NO_FAULT_DETECTED (0), UNRELIABLE_OTHER (7)	O	R
Out_Of_Service	BOOLEAN	FALSE	R	R
Update_Interval	Unsigned	-	O	-
Units	BACnetEngineeringUnits	Celsius degrees (62) Fahrenheit degrees (64)	R	R
Min_Pres_Value	REAL	-10°C / 14°F	O	-
Max_Pres_Value	REAL	50°C / 122°F	O	-
Resolution	REAL	-	O	-
COV_Increment	REAL	0	O	W
Time_Delay	Unsigned	-	O	-
Notification_Class	Unsigned	-	O	-
High_Limit	REAL	-	O	-
Low_Limit	REAL	-	O	-
Deadband	REAL	-	O	-
Limit_Enable	BACnetLimitEnable	-	O	-
Event_Enable	BACnetEventTransitionBits	-	O	-
Acked_Transitions	BACnetEventTransitionBits	-	O	-
Notify_Type	BACnetNotifyType	-	O	-
Event_Time_Stamps	BACnetArray[N] of BACnetTimeStamp	-	O	-
Profile_Name	CharacterString	-	O	-

7.1.3.13. RoomTemperature_command (Analog Output Object Type)

It sets the desired room temperature.

Property Identifier	Property Datatype	Value	ASHRAE	Gateway
Object_Identifier	BACnetObjectIdentifier	(Analog Output, 1)	R	R
Object_Name	CharacterString	RoomTemperature_command	R	R
Object_Type	BACnetObjectType	ANALOG_OUTPUT (1)	R	R
Present_Value	REAL	-10 .. 50°C / 14 .. 122°F	R	W
Description	CharacterString	-	O	-
Device_Type	CharacterString	-	O	-
Status_Flags	BACnetStatusFlags	{FALSE, FALSE, FALSE, FALSE}	R	R
Event_State	BACnetEventState	STATE_NORMAL (0)	R	R
Reliability	BACnetReliability	NO_FAULT_DETECTED (0)	O	R
Out_Of_Service	BOOLEAN	FALSE	R	R
Update_Interval	Unsigned	-	O	-
Units	BACnetEngineeringUnits	Celsius degrees (62) Fahrenheit degrees (64)	R	R
Min_Pres_Value	REAL	-	O	-
Max_Pres_Value	REAL	50°C / 122°F	O	-
Resolution	REAL	-	O	-
COV_Increment	REAL	0	O	W
Priority_Array	BACnetPriorityArray	BACnetPriorityArray	R	R
Relinquish_Default	Unsigned	-32768	R	W
Time_Delay	Unsigned	-	O	-
Notification_Class	Unsigned	-	O	-
High_Limit	REAL	-	O	-
Low_Limit	REAL	-	O	-
Deadband	REAL	-	O	-
Limit_Enable	BACnetLimitEnable	-	O	-
Event_Enable	BACnetEventTransitionBits	-	O	-
Acked_Transitions	BACnetEventTransitionBits	-	O	-
Notify_Type	BACnetNotifyType	-	O	-
Event_Time_Stamps	BACnetArray[N] of BACnetTimeStamp	-	O	-
Profile_Name	CharacterString	-	O	-



NOTE

You can set the temperature scale in Celsius or Fahrenheit scale via DIP switches. More information in [DIP Switches \(page 9\)](#).

7.1.3.14. ErrorCode (Analog Input Object Type)

It indicates the AC system's current error.

Property Identifier	Property Datatype	Value	ASHRAE	Gateway
Object_Identifier	BACnetObjectIdentifier	(Analog Input, 2)	R	R
Object_Name	CharacterString	ErrorCode	R	R
Object_Type	BACnetObjectType	ANALOG_INPUT (0)	R	R
Present_Value	REAL	-1 .. 349	R	R
Description	CharacterString	-	O	-
Device_Type	CharacterString	-	O	-
Status_Flags	BACnetStatusFlags	{FALSE, FALSE, FALSE, FALSE}	R	R
Event_State	BACnetEventState	STATE_NORMAL (0)	R	R
Reliability	BACnetReliability	NO_FAULT_DETECTED (0)	O	R
Out_Of_Service	BOOLEAN	FALSE	R	R
Update_Interval	Unsigned	300	O	-
Units	BACnetEngineeringUnits	NO_UNITS (95)	R	R
Min_Pres_Value	REAL	-1	O	-
Max_Pres_Value	REAL	6846	O	-
Resolution	REAL	-	O	-
COV_Increment	REAL	0	O	W
Time_Delay	Unsigned	-	O	-
Notification_Class	Unsigned	-	O	-
High_Limit	REAL	-	O	-
Low_Limit	REAL	-	O	-
Deadband	REAL	-	O	-
Limit_Enable	BACnetLimitEnable	-	O	-
Event_Enable	BACnetEventTransitionBits	-	O	-
Acked_Transitions	BACnetEventTransitionBits	-	O	-
Notify_Type	BACnetNotifyType	-	O	-
Event_Time_Stamps	BACnetArray[N] of BACnetTimeStamp	-	O	-
Profile_Name	CharacterString	-	O	-



NOTICE

For more information on each error code, see [Error Codes \(page 64\)](#).

7.1.3.15. ErrorCodeM (Multistate Input Object Type)

It indicates the AC system's current error.

Property Identifier	Property Datatype	Value	ASHRAE	Gateway
Object_Identifier	BACnetObjectIdentifier	(Multistate Input, 4)	R	R
Object_Name	CharacterString	ErrorCodeM	R	R
Object_Type	BACnetObjectType	MULTISTATE_INPUT(13)	R	R
Present_Value	Unsigned	1 .. 45	R	R
Description	CharacterString	-	O	-
Device_Type	CharacterString	-	O	-
Status_Flags	BACnetStatusFlags	{FALSE, FALSE, FALSE, FALSE}	R	R
Event_State	BACnetEventState	STATE_NORMAL (0)	R	R
Reliability	BACnetReliability	NO_FAULT_DETECTED (0)	O	R
Out_Of_Service	BOOLEAN	FALSE	R	R
Number_Of_States	Unsigned	44	R	R
State_Text	BACnetArray[N] of CharacterString	Check the Error codes table below	O	R
Time_Delay	Unsigned	-	O	-
Notification_Class	Unsigned	-	O	-
Alarm_Values	List of Unsigned	-	O	-
Fault_Values	List of Unsigned	-	O	-
Event_Enable	BACnetEventTransitionBits	-	O	-
Acked_Transitions	BACnetEventTransitionBits	-	O	-
Notify_Type	BACnetNotifyType	-	O	-
Event_Time_Stamps	BACnetArray[N] of BACnetTimeStamp	-	O	-
Profile_Name	CharacterString	-	O	-

Table 11. Error Codes

ErrorCodeM	State_Text	ErrorCodeM	State_Text	ErrorCodeM	State_Text
1	-	16	19	31	45
2	CommError	17	21	32	46
3	1	18	22	33	47
4	2	19	23	34	51
5	3	20	24	35	52
6	4	21	29	36	53
7	5	22	30	37	54
8	6	23	31	38	56
8	6.	24	32	39	57
9	7	25	35	40	58
10	8	26	36	41	b0
11	9	27	38	42	b1
12	11	28	39	43	b5
13	12	29	43	44	EE
14	13	30	44		

7.1.3.16. ErrorActive (Binary Input Object Type)

It indicates if there is an active error in the AC system.

Property Identifier	Property Datatype	Value	ASHRAE	Gateway
Object_Identifier	BACnetObjectIdentifier	(Binary Input, 1)	R	R
Object_Name	CharacterString	ErrorActive	R	R
Object_Type	BACnetObjectType	BINARY_INPUT (3)	R	R
Present_Value	BACnetBinaryPV	INACTIVE (0) / ACTIVE (1)	R	R
Description	CharacterString	-	O	-
Device_Type	CharacterString	-	O	-
Status_Flags	BACnetStatusFlags	{FALSE, FALSE, FALSE, FALSE}	R	R
Event_State	BACnetEventState	STATE_NORMAL (0)	R	R
Reliability	BACnetReliability	NO_FAULT_DETECTED (0)	O	R
Out_Of_Service	BOOLEAN	FALSE	R	R
Polarity	BACnetPolarity	NORMAL (0)	R	R
Inactive_Text	CharacterString	No	O	R
Active_Text	CharacterString	Error	O	R
Change_Of_State_Time	BACnetDatetime	-	O	-
Change_Of_State_Count	Unsigned	-	O	-
Time_Of_State_Count_Reset	BACnetDatetime	-	O	-
Elapsed_Active_Time	Unsigned	-	O	-
Time_Of_Active_Time_Reset	BACnetDatetime	-	O	-
Time_Delay	Unsigned	-	O	-
Notification_Class	Unsigned	-	O	-
Alarm_Value	BACnetBinaryPV	-	O	-
Event_Enable	BACnetEventTransitionBits	-	O	-
Acked_Transitions	BACnetEventTransitionBits	-	O	-
Notify_Type	BACnetNotifyType	-	O	-
Event_Time_Stamps	BACnetArray[N] of BACnetTimeStamp	-	O	-
Profile_Name	CharacterString	-	O	-

7.1.3.17. ErrorAddress (Analog Input Object Type)

It indicates the address of the indoor unit which is reporting the error.

Property Identifier	Property Datatype	Value	ASHRAE	Intesis
Object_Identifier	BACnetObjectIdentifier	(Analog Input, 4)	R	R
Object_Name	CharacterString	ErrorAddress	R	R
Object_Type	BACnetObjectType	ANALOG_INPUT (0)	R	R
Present_Value	REAL	-	R	R
Description	CharacterString	-	O	-
Device_Type	CharacterString	-	O	-
Status_Flags	BACnetStatusFlags	{FALSE, FALSE/TRUE, FALSE, FALSE}	R	R
Event_State	BACnetEventState	STATE_NORMAL (0)	R	R
Reliability	BACnetReliability	NO_FAULT_DETECTED (0) UNRELIABLE_OTHER (7)	O	R
Out_Of_Service	BOOLEAN	FALSE/TRUE	R	R
Update_Interval	Unsigned	-	O	-
Units	BACnetEngineeringUnits	NO_UNITS (95)	R	R
Min_Pres_Value	REAL	-	O	-
Max_Pres_Value	REAL	-	O	-
Resolution	REAL	-	O	-
COV_Increment	REAL	0	O	W
Time_Delay	Unsigned	-	O	-
Notification_Class	Unsigned	-	O	-
High_Limit	REAL	-	O	-
Low_Limit	REAL	-	O	-
Deadband	REAL	-	O	-
Limit_Enable	BACnetLimitEnable	-	O	-
Event_Enable	BACnetEventTransitionBits	-	O	-
Acked_Transitions	BACnetEventTransitionBits	-	O	-
Notify_Type	BACnetNotifyType	-	O	-
Event_Time_Stamps	BACnetArray[N] of BACnetTimeStamp	-	O	-
Profile_Name	CharacterString	-	O	-

7.1.3.18. ErrorReset (Binary Output Object Type)

It resets the error signal.

Property Identifier	Property Datatype	Value	ASHRAE	Intesis
Object_Identifier	BACnetObjectIdentifier	(Binary Output, 5)	R	R
Object_Name	CharacterString	ErrorReset	R	R
Object_Type	BACnetObjectType	BINARY_OUTPUT (4)	R	R
Present_Value	BACnetBinaryPV	INACTIVE (0) / ACTIVE (1)	R	W
Description	CharacterString	-	O	-
Device_Type	CharacterString	-	O	-
Status_Flags	BACnetStatusFlags	{FALSE, FALSE, FALSE, FALSE}	R	R
Event_State	BACnetEventState	STATE_NORMAL (0)	R	R
Reliability	BACnetReliability	NO_FAULT_DETECTED (0)	O	R
Out_Of_Service	BOOLEAN	FALSE	R	R
Polarity	BACnetPolarity	NORMAL (0)	R	R
Inactive_Text	CharacterString	Normal	O	R
Active_Text	CharacterString	Reset	O	R
Change_Of_State_Time	BACnetDatetime	-	O	-
Change_Of_State_Count	Unsigned	-	O	-
Time_Of_State_Count_Reset	BACnetDatetime	-	O	-
Elapsed_Active_Time	Unsigned	-	O	-
Time_Of_Active_Time_Reset	BACnetDatetime	-	O	-
Minimum_Off_Time	Unsigned32	-	O	-
Minimum_On_Time	Unsigned32	-	O	-
Priority_Array	BACnetPriorityArray	BACnetPriorityArray	R	R
Relinquish_Default	BACnetBinaryPV	INACTIVE (0)	R	R
Time Delay	Unsigned	-	O	-
Notification_Class	Unsigned	-	O	-
Feedback_Value	BACnetBinaryPV	-	O	-
Event_Enable	BACnetEventTransitionBits	-	O	-
Acked_Transitions	BACnetEventTransitionBits	-	O	-
Notify_Type	BACnetNotifyType	-	O	-
Event_Time_Stamps	BACnetArray[N] of BACnetTimeStamp	-	O	-
Profile_Name	CharacterString	-	O	-

7.1.3.19. OnTimeCounter (Analog Value Object Type)

It indicates the AC unit running time.

Property Identifier	Property Datatype	Value	ASHRAE	Gateway
Object_Identifier	BACnetObjectIdentifier	(Analog Value, 0)	R	R
Object_Name	CharacterString	OnTimeCounter	R	R
Object_Type	BACnetObjectType	ANALOG_VALUE (2)	R	R
Present_Value	REAL	0 .. 65535	R	R/W
Description	CharacterString	-	O	-
Status_Flags	BACnetStatusFlags	{FALSE, FALSE, FALSE, FALSE}	R	R
Event_State	BACnetEventState	STATE_NORMAL (0)	R	R
Reliability	BACnetReliability	NO_FAULT_DETECTED (0)	O	R
Out_Of_Service	BOOLEAN	FALSE	R	R
Update_Interval	Unsigned	-	O	-
Units	BACnetEngineeringUnits	Hours (71)	R	R
Min_Pres_Value	REAL	0	O	-
Max_Pres_Value	REAL	65535	O	-
Resolution	REAL	-	O	-
COV_Increment	REAL	0	O	W
Time_Delay	Unsigned	-	O	-
Notification_Class	Unsigned	-	O	-
High_Limit	REAL	-	O	-
Low_Limit	REAL	-	O	-
Deadband	REAL	-	O	-
Limit_Enable	BACnetLimitEnable	-	O	-
Event_Enable	BACnetEventTransitionBits	-	O	-
Acked_Transitions	BACnetEventTransitionBits	-	O	-
Notify_Type	BACnetNotifyType	-	O	-
Event_Time_Stamps	BACnetArray[N] of BACnetTimeStamp	-	O	-
Profile_Name	CharacterString	-	O	-

7.1.3.20. Occupancy (Multistate Value Object Type)

It indicates the current occupancy status.

Property Identifier	Property Datatype	Value	ASHRAE	Gateway
Object_Identifier	BACnetObjectIdentifier	(Multistate Output, 0)	R	R
Object_Name	CharacterString	Occupancy	R	R
Object_Type	BACnetObjectType	MULTISTATE_VALUE (19)	R	R
Present_Value	BACnetBinaryPV	1 .. 3	R	R/W
Description	CharacterString	-	O	-
Status_Flags	BACnetStatusFlags	{FALSE, FALSE, FALSE, FALSE}	R	R
Event_State	BACnetEventState	STATE_NORMAL (0)	R	R
Reliability	BACnetReliability	NO_FAULT_DETECTED (0)	O	R
Out_Of_Service	BOOLEAN	FALSE	R	R
Number_Of_States	Unsigned	3	R	R
State_Text	BACnetArray[N] of CharacterString	Check the Occupancy values table below	O	R
Priority_Array	BACnetPriorityArray	-	R	-
Relinquish_Default	Unsigned	-	R	-
Time_Delay	Unsigned	-	O	-
Notification_Class	Unsigned	-	O	-
Alarm_Value	Unsigned	-	O	-
Event_Enable	BACnetEventTransitionBits	-	O	-
Acked_Transitions	BACnetEventTransitionBits	-	O	-
Notify_Type	BACnetNotifyType	-	O	-
Event_Time_Stamps	BACnetArray[N] of BACnetTimeStamp	-	O	-
Profile_Name	CharacterString	-	O	-

Table 12. Occupancy values

Present_Value	State_Text
1	Occupied
2	Unoccupied
3	Disabled

7.1.3.21. OccupiedCoolSetPoint (Analog Value Object Type)

It indicates the temperature setpoint when the room is occupied, the cool mode is selected, and the occupancy object is enabled:

Property Identifier	Property Datatype	Value	ASHRAE	Gateway
Object_Identifier	BACnetObjectIdentifier	(Analog Value, 1)	R	R
Object_Name	CharacterString	OccupiedCoolSetPoint	R	R
Object_Type	BACnetObjectType	ANALOG_VALUE (2)	R	R
Present_Value	REAL	16 .. 32°C / 60 .. 90°F	R	R/W
Description	CharacterString	-	O	-
Status_Flags	BACnetStatusFlags	{FALSE, FALSE, FALSE, FALSE}	R	R
Event_State	BACnetEventState	STATE_NORMAL (0)	R	R
Reliability	BACnetReliability	NO_FAULT_DETECTED (0)	O	R
Out_Of_Service	BOOLEAN	FALSE	R	R
Update_Interval	Unsigned	-	O	-
Units	BACnetEngineeringUnits	Degrees Celsius (62) Degrees Fahrenheit (64)	R	R
Min_Pres_Value	REAL	0	O	-
Max_Pres_Value	REAL	65535	O	-
Resolution	REAL	-	O	-
COV_Increment	REAL	0	O	W
Time_Delay	Unsigned	-	O	-
Notification_Class	Unsigned	-	O	-
High_Limit	REAL	-	O	-
Low_Limit	REAL	-	O	-
Deadband	REAL	-	O	-
Limit_Enable	BACnetLimitEnable	-	O	-
Event_Enable	BACnetEventTransitionBits	-	O	-
Acked_Transitions	BACnetEventTransitionBits	-	O	-
Notify_Type	BACnetNotifyType	-	O	-
Event_Time_Stamps	BACnetArray[N] of BACnetTimeStamp	-	O	-
Profile_Name	CharacterString	-	O	-



NOTE

You can set the temperature scale in Celsius or Fahrenheit scale via DIP switches. More information in [DIP Switches \(page 9\)](#).

7.1.3.22. OccupiedHeatSetPoint (Analog Value Object Type)

It indicates the temperature setpoint when the room is occupied, the heat mode is selected, and the occupancy object is enabled.

Property Identifier	Property Datatype	Value	ASHRAE	Gateway
Object_Identifier	BACnetObjectIdentifier	(Analog Value, 2)	R	R
Object_Name	CharacterString	OccupiedHeatSetPoint	R	R
Object_Type	BACnetObjectType	ANALOG_VALUE (2)	R	R
Present_Value	REAL	16 .. 32°C / 60 .. 90°F	R	R/W
Description	CharacterString	-	O	-
Status_Flags	BACnetStatusFlags	{FALSE, FALSE, FALSE, FALSE}	R	R
Event_State	BACnetEventState	STATE_NORMAL (0)	R	R
Reliability	BACnetReliability	NO_FAULT_DETECTED (0)	O	R
Out_Of_Service	BOOLEAN	FALSE	R	R
Update_Interval	Unsigned	-	O	-
Units	BACnetEngineeringUnits	Degrees Celsius (62) Degrees Fahrenheit (64)	R	R
Min_Pres_Value	REAL	16°C / 60°F	O	-
Max_Pres_Value	REAL	32°C / 90°F	O	-
Resolution	REAL	-	O	-
COV_Increment	REAL	0	O	W
Time_Delay	Unsigned	-	O	-
Notification_Class	Unsigned	-	O	-
High_Limit	REAL	-	O	-
Low_Limit	REAL	-	O	-
Deadband	REAL	-	O	-
Limit_Enable	BACnetLimitEnable	-	O	-
Event_Enable	BACnetEventTransitionBits	-	O	-
Acked_Transitions	BACnetEventTransitionBits	-	O	-
Notify_Type	BACnetNotifyType	-	O	-
Event_Time_Stamps	BACnetArray[N] of BACnetTimeStamp	-	O	-
Profile_Name	CharacterString	-	O	-



NOTE

You can set the temperature scale in Celsius or Fahrenheit scale via DIP switches. More information in [DIP Switches \(page 9\)](#).

7.1.3.23. UnoccupiedCoolSetPoint (Analog Value Object Type)

It indicates the setpoint when the room is unoccupied, the cool mode is selected, and the occupancy object is enabled.

Property Identifier	Property Datatype	Value	ASHRAE	Gateway
Object_Identifier	BACnetObjectIdentifier	(Analog Value, 3)	R	R
Object_Name	CharacterString	UnoccupiedCoolSetPoint	R	R
Object_Type	BACnetObjectType	ANALOG_VALUE (2)	R	R
Present_Value	REAL	16 .. 32°C / 60 .. 90°F	R	R/W
Description	CharacterString	-	O	-
Status_Flags	BACnetStatusFlags	{FALSE, FALSE, FALSE, FALSE}	R	R
Event_State	BACnetEventState	STATE_NORMAL (0)	R	R
Reliability	BACnetReliability	NO_FAULT_DETECTED (0)	O	R
Out_Of_Service	BOOLEAN	FALSE	R	R
Update_Interval	Unsigned	-	O	-
Units	BACnetEngineeringUnits	Degrees Celsius (62) Degrees Fahrenheit (64)	R	R
Min_Pres_Value	REAL	16°C / 60°F	O	-
Max_Pres_Value	REAL	32°C / 90°F	O	-
Resolution	REAL	-	O	-
COV_Increment	REAL	0	O	W
Time_Delay	Unsigned	-	O	-
Notification_Class	Unsigned	-	O	-
High_Limit	REAL	-	O	-
Low_Limit	REAL	-	O	-
Deadband	REAL	-	O	-
Limit_Enable	BACnetLimitEnable	-	O	-
Event_Enable	BACnetEventTransitionBits	-	O	-
Acked_Transitions	BACnetEventTransitionBits	-	O	-
Notify_Type	BACnetNotifyType	-	O	-
Event_Time_Stamps	BACnetArray[N] of BACnetTimeStamp	-	O	-
Profile_Name	CharacterString	-	O	-



NOTE

You can set the temperature scale in Celsius or Fahrenheit scale via DIP switches. More information in [DIP Switches \(page 9\)](#).

7.1.3.24. UnoccupiedHeatSetPoint (Analog Value Object Type)

It indicates the setpoint temperature when the room is unoccupied, the heat mode is selected, and the occupancy object is enabled.

Property Identifier	Property Datatype	Value	ASHRAE	Gateway
Object_Identifier	BACnetObjectIdentifier	(Analog Value, 4)	R	R
Object_Name	CharacterString	UnoccupiedHeatSetPoint	R	R
Object_Type	BACnetObjectType	ANALOG_VALUE (2)	R	R
Present_Value	REAL	16 .. 32°C / 60 .. 90°F	R	R/W
Description	CharacterString	-	O	-
Status_Flags	BACnetStatusFlags	{FALSE, FALSE, FALSE, FALSE}	R	R
Event_State	BACnetEventState	STATE_NORMAL (0)	R	R
Reliability	BACnetReliability	NO_FAULT_DETECTED (0)	O	R
Out_Of_Service	BOOLEAN	FALSE	R	R
Update_Interval	Unsigned	-	O	-
Units	BACnetEngineeringUnits	Degrees Celsius (62) Degrees Fahrenheit (64)	R	R
Min_Pres_Value	REAL	16°C / 60°F	O	-
Max_Pres_Value	REAL	32°C / 90°F	O	-
Resolution	REAL	-	O	-
COV_Increment	REAL	0	O	W
Time_Delay	Unsigned	-	O	-
Notification_Class	Unsigned	-	O	-
High_Limit	REAL	-	O	-
Low_Limit	REAL	-	O	-
Deadband	REAL	-	O	-
Limit_Enable	BACnetLimitEnable	-	O	-
Event_Enable	BACnetEventTransitionBits	-	O	-
Acked_Transitions	BACnetEventTransitionBits	-	O	-
Notify_Type	BACnetNotifyType	-	O	-
Event_Time_Stamps	BACnetArray[N] of BACnetTimeStamp	-	O	-
Profile_Name	CharacterString	-	O	-



NOTE

You can set the temperature scale in Celsius or Fahrenheit scale via DIP switches. More information in [DIP Switches \(page 9\)](#).

7.1.3.25. OccupancyContinuousCheck (Binary Value Object Type)

It indicates if the system is continuously checking the setpoint and occupancy conditions.

Property Identifier	Property Datatype	Value	ASHRAE	Gateway
Object_Identifier	BACnetObjectIdentifier	(Binary Value, 0)	R	R
Object_Name	CharacterString	OccupancyContinuousCheck	R	R
Object_Type	BACnetObjectType	BINARY_VALUE (5)	R	R
Present_Value	BACnetBinaryPV	INACTIVE (0) / ACTIVE (1)	R	R/W
Description	CharacterString	-	O	-
Status_Flags	BACnetStatusFlags	{FALSE, FALSE, FALSE, FALSE}	R	R
Event_State	BACnetEventState	STATE_NORMAL (0)	R	R
Reliability	BACnetReliability	NO_FAULT_DETECTED (0)	O	R
Out_Of_Service	BOOLEAN	FALSE	R	R
Inactive_Text	CharacterString	Disabled	O	R
Active_Text	CharacterString	Enabled	O	R
Change_Of_State_Time	BACnetDatetime	-	O	-
Change_Of_State_Count	Unsigned	-	O	-
Time_Of_State_Count_Reset	BACnetDatetime	-	O	-
Elapsed_Active_Time	Unsigned	-	O	-
Time_Of_Active_Time_Reset	BACnetDatetime	-	O	-
Minimum_Off_Time	Unsigned32	-	O	-
Minimum_On_Time	Unsigned32	-	O	-
Priority_Array	BACnetPriorityArray	BACnetPriorityArray	R	-
Relinquish_Default	BACnetBinaryPV	INACTIVE (0)	R	-
Time_Delay	Unsigned	-	O	-
Notification_Class	Unsigned	-	O	-
Alarm_Value	BACnetBinaryPV	-	O	-
Event_Enable	BACnetEventTransitionBits	-	O	-
Acked_Transitions	BACnetEventTransitionBits	-	O	-
Notify_Type	BACnetNotifyType	-	O	-
Event_Time_Stamps	BACnetArray[N] of BACnetTimeStamp	-	O	-
Profile_Name	CharacterString	-	O	-

7.1.3.26. UnoccupiedDeadbandAction (Binary Value Object Type)

It indicates the action to be performed when Unoccupancy is enabled, and Room Temperature is within the deadband.

Property Identifier	Property Datatype	Value	ASHRAE	Gateway
Object_Identifier	BACnetObjectIdentifier	(Binary Value, 1)	R	R
Object_Name	CharacterString	UnoccupiedDeadbandAction	R	R
Object_Type	BACnetObjectType	BINARY_VALUE (5)	R	R
Present_Value	BACnetBinaryPV	INACTIVE (0) / ACTIVE (1)	R	R/W
Description	CharacterString	-	O	-
Status_Flags	BACnetStatusFlags	{FALSE, FALSE, FALSE, FALSE}	R	R
Event_State	BACnetEventState	STATE_NORMAL (0)	R	R
Reliability	BACnetReliability	NO_FAULT_DETECTED (0)	O	R
Out_Of_Service	BOOLEAN	FALSE	R	R
Inactive_Text	CharacterString	Off	O	R
Active_Text	CharacterString	CurrentMode	O	R
Change_Of_State_Time	BACnetDatetime	-	O	-
Change_Of_State_Count	Unsigned	-	O	-
Time_Of_State_Count_Reset	BACnetDatetime	-	O	-
Elapsed_Active_Time	Unsigned	-	O	-
Time_Of_Active_Time_Reset	BACnetDatetime	-	O	-
Minimum_Off_Time	Unsigned32	-	O	-
Minimum_On_Time	Unsigned32	-	O	-
Priority_Array	BACnetPriorityArray	BACnetPriorityArray	R	-
Relinquish_Default	BACnetBinaryPV	INACTIVE (0)	R	-
Time_Delay	Unsigned	-	O	-
Notification_Class	Unsigned	-	O	-
Alarm_Value	BACnetBinaryPV	-	O	-
Event_Enable	BACnetEventTransitionBits	-	O	-
Acked_Transitions	BACnetEventTransitionBits	-	O	-
Notify_Type	BACnetNotifyType	-	O	-
Event_Time_Stamps	BACnetArray[N] of BACnetTimeStamp	-	O	-
Profile_Name	CharacterString	-	O	-

7.1.3.27. SerialNumber (Analog Input Object Type)

It indicates the serial number of the gateway with the pattern **000EXXXXX**, where:

- **000E** is constant and not included in the Present Value property.
- **XXXXX** is the unique device serial number. This is the information provided by the Present Value.

Property Identifier	Property Datatype	Value	ASHRAE	Gateway
Object_Identifier	BACnetObjectIdentifier	(Analog Input, 11)	R	R
Object_Name	CharacterString	SerialNumber	R	R
Object_Type	BACnetObjectType	ANALOG_INPUT (0)	R	R
Present_Value	BACnetBinaryPV	00000 .. 99999	R	R
Description	CharacterString	-	O	-
Device_Type	CharacterString	-	O	-
Status_Flags	BACnetStatusFlags	{FALSE, FALSE, FALSE, FALSE}	R	R
Event_State	BACnetEventState	STATE_NORMAL (0)	R	R
Reliability	BACnetReliability	NO_FAULT_DETECTED (0)	O	R
Polarity	BACnetPolarity	NORMAL (0)	R	R
Change_Of_State_Time	BACnetDatetime	-	O	-
Change_Of_State_Count	Unsigned	-	O	-
Time_Of_State_Count_Reset	BACnetDatetime	-	O	-
Elapsed_Active_Time	Unsigned	-	O	-
Time_Of_Active_Time_Reset	BACnetDatetime	-	O	-
Time_Delay	Unsigned	-	O	-
Notification_Class	Unsigned	-	O	-
Alarm_Value	BACnetBinaryPV	-	O	-
Event_Enable	BACnetEventTransitionBits	-	O	-
Acked_Transitions	BACnetEventTransitionBits	-	O	-
Notify_Type	BACnetNotifyType	-	O	-
Event_Time_Stamps	BACnetArray[N] of BACnetTimeStamp	-	O	-
Profile_Name	CharacterString	-	O	-
Units	BACnetEngineeringUnits	No units (95)	R	R
COV_Increment	REAL	0	O	W

7.1.3.28. LockRemoteControl (Binary Value Object Type)

It is used to lock or unlock the indoor unit infrared remote controller.

Property Identifier	Property Datatype	Value	ASHRAE	Gateway
Object_Identifier	BACnetObjectIdentifier	(Binary Value, 2)	R	R
Object_Name	CharacterString	LockRemoteControl	R	R
Object_Type	BACnetObjectType	BINARY_VALUE (5)	R	R
Present_Value	BACnetBinaryPV	INACTIVE (0) / ACTIVE (1)	R	R/W
Description	CharacterString	-	O	-
Status_Flags	BACnetStatusFlags	{FALSE, FALSE, FALSE, FALSE}	R	R
Event_State	BACnetEventState	STATE_NORMAL (0)	R	R
Reliability	BACnetReliability	NO_FAULT_DETECTED (0)	O	R
Out_Of_Service	BOOLEAN	FALSE	R	R
Inactive_Text	CharacterString	Unlocked	O	R
Active_Text	CharacterString	Locked	O	R
Change_Of_State_Time	BACnetDatetime	-	O	-
Change_Of_State_Count	Unsigned	-	O	-
Time_Of_State_Count_Reset	BACnetDatetime	-	O	-
Elapsed_Active_Time	Unsigned	-	O	-
Time_Of_Active_Time_Reset	BACnetDatetime	-	O	-
Minimum_Off_Time	Unsigned32	-	O	-
Minimum_On_Time	Unsigned32	-	O	-
Priority_Array	BACnetPriorityArray	BACnetPriorityArray	R	-
Relinquish_Default	BACnetBinaryPV	INACTIVE (0)	R	-
Time_Delay	Unsigned	-	O	-
Notification_Class	Unsigned	-	O	-
Alarm_Value	BACnetBinaryPV	-	O	-
Event_Enable	BACnetEventTransitionBits	-	O	-
Acked_Transitions	BACnetEventTransitionBits	-	O	-
Notify_Type	BACnetNotifyType	-	O	-
Event_Time_Stamps	BACnetArray[N] of BACnetTimeStamp	-	O	-
Profile_Name	CharacterString	-	O	-

7.1.3.29. UserSetPoint_status (Analog Input Object Type)

It indicates the current BACnet setpoint temperature when the virtual temperature object is active. See [VirtualTemperatureActive \(Binary Input Object Type\) \(page 45\)](#).

Property Identifier	Property Datatype	Value	ASHRAE	Gateway
Object_Identifier	BACnetObjectIdentifier	(Analog Input, 17)	R	R
Object_Name	CharacterString	UserSetPoint_status	R	R
Object_Type	BACnetObjectType	ANALOG_INPUT (0)	R	R
Present_Value	REAL	10 .. 32°C / 50 .. 90°F	R	R
Description	CharacterString	-	O	-
Device_Type	CharacterString	-	O	-
Status_Flags	BACnetStatusFlags	{FALSE, FALSE, FALSE, FALSE}	R	R
Event_State	BACnetEventState	STATE_NORMAL (0)	R	R
Reliability	BACnetReliability	NO_FAULT_DETECTED (0) UNRELIABLE_OTHER (7)	O	R
Out_Of_Service	BOOLEAN	FALSE	R	R
Update_Interval	Unsigned	300	O	-
Units	BACnetEngineeringUnits	Celsius degrees (62) Fahrenheit degrees (64)	R	R
Min_Pres_Value	REAL	10°C / 50°F	O	-
Max_Pres_Value	REAL	32°C / 90°F	O	-
Resolution	REAL	-	O	-
COV_Increment	REAL	0	O	W
Time_Delay	Unsigned	-	O	-
Notification_Class	Unsigned	-	O	-
High_Limit	REAL	-	O	-
Low_Limit	REAL	-	O	-
Deadband	REAL	-	O	-
Limit_Enable	BACnetLimitEnable	-	O	-
Event_Enable	BACnetEventTransitionBits	-	O	-
Acked_Transitions	BACnetEventTransitionBits	-	O	-
Notify_Type	BACnetNotifyType	-	O	-
Event_Time_Stamps	BACnetArray[N] of BACnetTimeStamp	-	O	-
Profile_Name	CharacterString	-	O	-

7.1.3.30. VirtualTemperatureActive (Binary Input Object Type)

It indicates if the virtual temperature function is active or not. For more information on this function, see [Considerations on BACnet Temperature Objects \(page 54\)](#).

Property Identifier	Property Datatype	Value	ASHRAE	Gateway
Object_Identifier	BACnetObjectIdentifier	(Binary Input, 14)	R	R
Object_Name	CharacterString	VirtualTempActive	R	R
Object_Type	BACnetObjectType	BINARY_INPUT (3)	R	R
Present_Value	BACnetBinaryPV	INACTIVE (0) / ACTIVE (1)	R	R
Description	CharacterString	-	O	-
Device_Type	CharacterString	-	O	-
Status_Flags	BACnetStatusFlags	{FALSE, FALSE, FALSE, FALSE}	R	R
Event_State	BACnetEventState	STATE_NORMAL (0)	R	R
Reliability	BACnetReliability	NO_FAULT_DETECTED (0) UNRELIABLE_OTHER (7)	O	R
Out_Of_Service	BOOLEAN	FALSE	R	R
Polarity	BACnetPolarity	NORMAL (0)	R	R
Inactive_Text	CharacterString	No	O	R
Active_Text	CharacterString	Yes	O	R
Change_Of_State_Time	BACnetDatetime	-	O	-
Change_Of_State_Count	Unsigned	-	O	-
Time_Of_State_Count_Reset	BACnetDatetime	-	O	-
Elapsed_Active_Time	Unsigned	-	O	-
Time_Of_Active_Time_Reset	BACnetDatetime	-	O	-
Time_Delay	Unsigned	-	O	-
Notification_Class	Unsigned	-	O	-
Alarm_Value	BACnetBinaryPV	-	O	-
Event_Enable	BACnetEventTransitionBits	-	O	-
Acked_Transitions	BACnetEventTransitionBits	-	O	-
Notify_Type	BACnetNotifyType	-	O	-
Event_Time_Stamps	BACnetArray[N] of BACnetTimeStamp	-	O	-
Profile_Name	CharacterString	-	O	-

7.1.3.31. FilterSignAddress (Analog Input Object Type)switches

It indicates the AC indoor unit address reporting the filter signal.

Property Identifier	Property Datatype	Value	ASHRAE	Intesis
Object_Identifier	BACnetObjectIdentifier	(Analog Input, 18)	R	R
Object_Name	CharacterString	FilterSignAddress	R	R
Object_Type	BACnetObjectType	ANALOG_INPUT (0)	R	R
Present_Value	REAL	-	R	R
Description	CharacterString	-	O	-
Device_Type	CharacterString	-	O	-
Status_Flags	BACnetStatusFlags	{FALSE, FALSE, FALSE, FALSE}	R	R
Event_State	BACnetEventState	STATE_NORMAL (0)	R	R
Reliability	BACnetReliability	NO_FAULT_DETECTED (0) UNRELIABLE_OTHER (7)	O	R
Out_Of_Service	BOOLEAN	FALSE	R	R
Update_Interval	Unsigned	-	O	-
Units	BACnetEngineeringUnits	-	R	R
Min_Pres_Value	REAL	-	O	-
Max_Pres_Value	REAL	-	O	-
Resolution	REAL	-	O	-
COV_Increment	REAL	0	O	W
Time_Delay	Unsigned	-	O	-
Notification_Class	Unsigned	-	O	-
High_Limit	REAL	-	O	-
Low_Limit	REAL	-	O	-
Deadband	REAL	-	O	-
Limit_Enable	BACnetLimitEnable	-	O	-
Event_Enable	BACnetEventTransitionBits	-	O	-
Acked_Transitions	BACnetEventTransitionBits	-	O	-
Notify_Type	BACnetNotifyType	-	O	-
Event_Time_Stamps	BACnetArray[N] of BACnetTimeStamp	-	O	-
Profile_Name	CharacterString	-	O	-

7.1.3.32. DIP_SW_S1_status (Analog Input Object Type)

It indicates the status of the DIP switch block SW1 in decimal value. To get the status of each individual switch of SW1, just convert it to binary. The gateway reads this value only when booting up.

Property Identifier	Property Datatype	Value	ASHRAE	Gateway
Object_Identifier	BACnetObjectIdentifier	(Analog Input, 9)	R	R
Object_Name	CharacterString	DIP_SW_S1_status	R	R
Object_Type	BACnetObjectType	ANALOG_INPUT (0)	R	R
Present_Value	BACnetBinaryPV	0 .. 255	R	R
Description	CharacterString	-	O	-
Device_Type	CharacterString	-	O	-
Status_Flags	BACnetStatusFlags	{FALSE, FALSE, FALSE, FALSE}	R	R
Event_State	BACnetEventState	STATE_NORMAL (0)	R	R
Reliability	BACnetReliability	NO_FAULT_DETECTED (0)	O	R
Out_Of_Service	BOOLEAN	FALSE / TRUE	R	R
Change_Of_State_Time	BACnetDatetime	-	O	-
Change_Of_State_Count	Unsigned	-	O	-
Time_Of_State_Count_Reset	BACnetDatetime	-	O	-
Elapsed_Active_Time	Unsigned	-	O	-
Time_Of_Active_Time_Reset	BACnetDatetime	-	O	-
Time_Delay	Unsigned	-	O	-
Notification_Class	Unsigned	-	O	-
Alarm_Value	BACnetBinaryPV	-	O	-
Event_Enable	BACnetEventTransitionBits	-	O	-
Acked_Transitions	BACnetEventTransitionBits	-	O	-
Notify_Type	BACnetNotifyType	-	O	-
Event_Time_Stamps	BACnetArray[N] of BACnetTimeStamp	-	O	-
Profile_Name	CharacterString	-	O	-
Units	BACnetEngineeringUnits	No units (95)	R	R
COV_Increment	REAL	0	O	W

7.1.3.33. DIP_SW_S2_status (Analog Input Object Type)

It indicates the status of the DIP switch block SW2 in decimal value. To get the status of each individual switch of SW2, just convert it to binary. The gateway reads this value only when booting up.s

Property Identifier	Property Datatype	Value	ASHRAE	Gateway
Object_Identifier	BACnetObjectIdentifier	(Analog Input, 10)	R	R
Object_Name	CharacterString	DIP_SW_S2_status	R	R
Object_Type	BACnetObjectType	ANALOG_INPUT (0)	R	R
Present_Value	BACnetBinaryPV	0 .. 255	R	R
Description	CharacterString	-	O	-
Device_Type	CharacterString	-	O	-
Status_Flags	BACnetStatusFlags	{FALSE, FALSE, FALSE, FALSE}	R	R
Event_State	BACnetEventState	STATE_NORMAL (0)	R	R
Reliability	BACnetReliability	NO_FAULT_DETECTED (0)	O	R
Out_Of_Service	BOOLEAN	FALSE / TRUE	R	R
Change_Of_State_Time	BACnetDatetime	-	O	-
Change_Of_State_Count	Unsigned	-	O	-
Time_Of_State_Count_Reset	BACnetDatetime	-	O	-
Elapsed_Active_Time	Unsigned	-	O	-
Time_Of_Active_Time_Reset	BACnetDatetime	-	O	-
Time_Delay	Unsigned	-	O	-
Notification_Class	Unsigned	-	O	-
Alarm_Value	BACnetBinaryPV	-	O	-
Event_Enable	BACnetEventTransitionBits	-	O	-
Acked_Transitions	BACnetEventTransitionBits	-	O	-
Notify_Type	BACnetNotifyType	-	O	-
Event_Time_Stamps	BACnetArray[N] of BACnetTimeStamp	-	O	-
Profile_Name	CharacterString	-	O	-
Units	BACnetEngineeringUnits	No units (95)	R	R
COV_Increment	REAL	0	O	W

7.1.3.34. FilterSign (Binary Input Object Type)

It indicates the status of the filter, if there's an error or not.

Property Identifier	Property Datatype	Value	ASHRAE	Intesis
Object_Identifier	BACnetObjectIdentifier	(Binary Input, 1)	R	R
Object_Name	CharacterString	FilterSign	R	R
Object_Type	BACnetObjectType	BINARY_OUTPUT (4)	R	R
Present_Value	BACnetBinaryPV	INACTIVE (0) / ACTIVE (1)	R	R
Description	CharacterString	-	O	-
Device_Type	CharacterString	-	O	-
Status_Flags	BACnetStatusFlags	{FALSE, FALSE/TRUE, FALSE, FALSE}	R	R
Event_State	BACnetEventState	STATE_NORMAL (0)	R	R
Reliability	BACnetReliability	NO_FAULT_DETECTED (0) UNRELIABLE_OTHER (7)	O	R
Out_Of_Service	BOOLEAN	FALSE	R	R
Polarity	BACnetPolarity	NORMAL (0)	R	R
Inactive_Text	CharacterString	OK	O	R
Active_Text	CharacterString	Dirty	O	R
Change_Of_State_Time	BACnetDatetime	-	O	-
Change_Of_State_Count	Unsigned	-	O	-
Time_Of_State_Count_Reset	BACnetDatetime	-	O	-
Elapsed_Active_Time	Unsigned	-	O	-
Time_Of_Active_Time_Reset	BACnetDatetime	-	O	-
Time_Delay	Unsigned	-	O	-
Notification_Class	Unsigned	-	O	-
Feedback_Value	BACnetBinaryPV	-	O	-
Event_Enable	BACnetEventTransitionBits	-	O	-
Acked_Transitions	BACnetEventTransitionBits	-	O	-
Notify_Type	BACnetNotifyType	-	O	-
Event_Time_Stamps	BACnetArray[N] of BACnetTimeStamp	-	O	-
Profile_Name	CharacterString	-	O	-

7.1.3.35. FilterReset (Binary Output Object Type)

It resets the filter signal.

Property Identifier	Property Datatype	Value	ASHRAE	Intesis
Object_Identifier	BACnetObjectIdentifier	(Binary Output, 4)	R	R
Object_Name	CharacterString	FilterReset	R	R
Object_Type	BACnetObjectType	BINARY_OUTPUT (4)	R	R
Present_Value	BACnetBinaryPV	INACTIVE (0) / ACTIVE (1)	W	W
Description	CharacterString	-	O	-
Device_Type	CharacterString	-	O	-
Status_Flags	BACnetStatusFlags	{FALSE, FALSE, FALSE, FALSE}	R	R
Event_State	BACnetEventState	STATE_NORMAL (0)	R	R
Reliability	BACnetReliability	NO_FAULT_DETECTED (0)	O	R
Out_Of_Service	BOOLEAN	FALSE	R	R
Polarity	BACnetPolarity	NORMAL (0)	R	R
Inactive_Text	CharacterString	Normal	O	R
Active_Text	CharacterString	Reset	O	R
Change_Of_State_Time	BACnetDatetime	-	O	-
Change_Of_State_Count	Unsigned	-	O	-
Time_Of_State_Count_Reset	BACnetDatetime	-	O	-
Elapsed_Active_Time	Unsigned	-	O	-
Time_Of_Active_Time_Reset	BACnetDatetime	-	O	-
Minimum_Off_Time	Unsigned32	-	O	-
Minimum_On_Time	Unsigned32	-	O	-
Priority_Array	BACnetPriorityArray	BACnetPriorityArray	R	R
Relinquish_Default	BACnetBinaryPV	INACTIVE (0)	R	R
Time Delay	Unsigned	-	O	-
Notification_Class	Unsigned	-	O	-
Feedback_Value	BACnetBinaryPV	-	O	-
Event_Enable	BACnetEventTransitionBits	-	O	-
Acked_Transitions	BACnetEventTransitionBits	-	O	-
Notify_Type	BACnetNotifyType	-	O	-
Event_Time_Stamps	BACnetArray[N] of BACnetTimeStamp	-	O	-
Profile_Name	CharacterString	-	O	-

7.1.3.36. ResetBehaviour (Multistate Value Object Type)

It indicates the Reset behavior of the gateway.

Property Identifier	Property Datatype	Value	ASHRAE	Intesis
Object_Identifier	BACnetObjectIdentifier	(Multistate Value, 4)	R	R
Object_Name	CharacterString	ResetBehaviour	R	R
Object_Type	BACnetObjectType	MULTISTATE_Value (19)	R	R
Present_Value	Unsigned	1 .. 2	R	R
Description	CharacterString	-	O	-
Device_Type	CharacterString	-	O	-
Status_Flags	BACnetStatusFlags	{FALSE, FALSE/TRUE, FALSE, FALSE}	R	R
Event_State	BACnetEventState	STATE_NORMAL (0)	R	R
Reliability	BACnetReliability	NO_FAULT_DETECTED (0), UNRELIABLE_OTHER (7)	O	R
Out_Of_Service	BOOLEAN	FALSE/TRUE	R	R
Number_Of_States	Unsigned	2	R	R
State_Text	BACnetArray[N] of CharacterString	Check the ResetBehavior setting table below.	O	R
Time_Delay	Unsigned	-	O	-
Notification_Class	Unsigned	-	O	-
Alarm_Values	List of Unsigned	-	O	-
Fault_Values	List of Unsigned	-	O	-
Event_Enable	BACnetEventTransitionBits	-	O	-
Acked_Transitions	BACnetEventTransitionBits	-	O	-
Notify_Type	BACnetNotifyType	-	O	-
Event_Time_Stamps	BACnetArray[N] of BACnetTimeStamp	-	O	-
Profile_Name	CharacterString	-	O	-

ResetBehaviour interpretation is possible using the value in the following correspondence table.

Table 13. ResetBehavior setting table

Present_Value	Contents displayed in State_Text
1	Store AC status
2	Do not store AC status

7.2. Occupancy



IMPORTANT

This function requires an external sensor on the control system (BMS) side to detect if there's someone in the room.

The occupancy function determines the AC unit behavior depending on the presence or absence of people in the room. This signal is processed directly in the Intesis gateway and modifies three parameters from the AC system: Setpoint, Mode, and On/Off.

To adjust the settings for the current mode (Heat or Cool), the gateway offers six different BACnet objects:

- OccupiedCoolSetPoint
- OccupiedHeatSetPoint
- UnoccupiedCoolSetPoint
- UnoccupiedHeatSetPoint
- OccupancyContinousCheck

- UnoccupiedDeadbandAction

Figure 5. Temperature setpoint settings

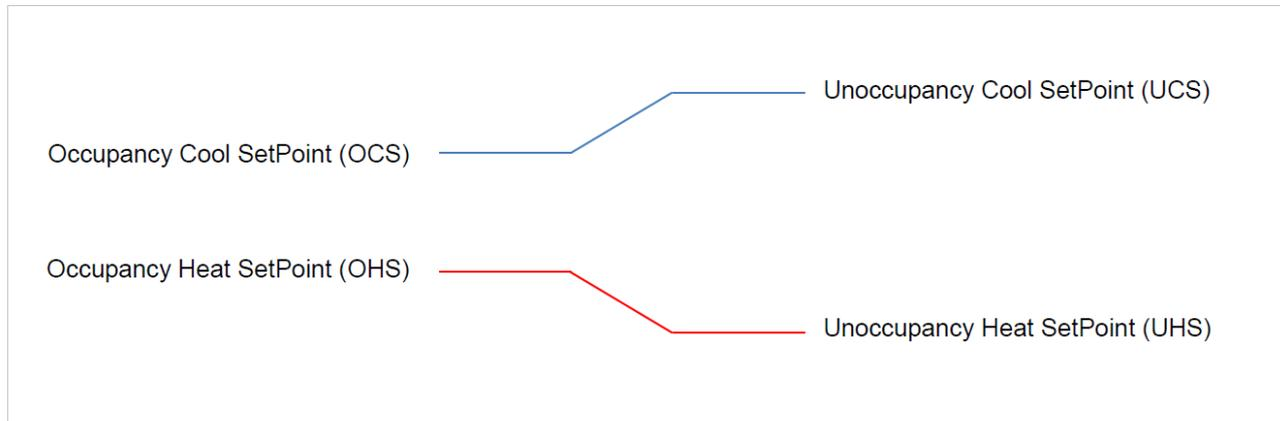
**NOTICE**

The minimum difference between Cool and Heat setpoints must be 2°C / 4°F.

Occupancy/Unoccupancy Cool SetPoint (OCS/UCS): This is the default value for the setpoint temperature when the current mode is Cool, and Occupancy / Unoccupancy is enabled. UCS must always be greater or equal to OCS. The difference between OCS and OHS must be greater or equal to 2°C / 4°F.

Occupancy/Unoccupancy Heat SetPoint (OHS/UHS): This is the default value for the setpoint temperature when the current mode is Heat, and Occupancy / Unoccupancy is enabled. UHS must always be smaller or equal to OHS. The difference between OCS and OHS must be greater or equal to 2°C / 4°F.

Occupancy Continuous check: It determines when the gateway checks the occupancy:

- If the parameter is checked, the gateway checks the occupancy when there's any change in the room's temperature.
- If the parameter is unchecked, it only checks the occupancy when the occupancy status changes.

Unoccupied Deadband Action: This determines the AC unit behavior while the ambient temperature is in between the deadband. If unchecked, the indoor unit will turn off; if checked, it will remain on.

When **Occupancy mode** is active (there is presence in the room), according to current room temperature, **mode**, **setpoint**, and **on/off** will be set to:

Condition	Setpoint	Mode	On/Off
Room temperature > OCS	Current OCS value	Cool	On
Room temperature < OHS	Current OCS value	Heat	On
OCS < Room temperature > OHS	OCS/OHS depending on the current mode (If Fan or Dry mode is active, no setpoint is sent)	Current mode	On

When **Unoccupancy mode** is active (there is no presence in the room), according to current room temperature, **mode, setpoint** and **on/off** will be set to:

Condition	Setpoint	Mode	On/Off
Room temperature > OCS	Current UCS value	Cool	On
Room temperature < OHS	Current UHS value	Heat	On
OCS < Room temperature > OHS	UCS/UHS depending on the current mode (If Fan or Dry mode is active, no setpoint is sent)	Current mode	On (Deadband action=1)
			Off (Deadband action=0)

The room temperature is cross-checked against temperature settings as described above when:

- The AC indoor unit occupancy status changes.
- The room temperature changes (only if the **check continuously** function is enabled).



NOTICE

Any local change (for example with the remote control) in the Setpoint, Mode, or the On/Off signal will disable the Occupancy functionality.

7.3. Considerations on BACnet Temperature Objects

- **Setpoint_command (Analog Output Object Type)**

This is the temperature setpoint requested by the user. This value can be read and written.



NOTICE

A remote controller connected to the indoor unit will report the same temperature setpoint value as set in this object *when there's no VT active*. See *VT*

- **RoomTemperature_status (Analog Input Object Type)**

This read-only object reports the temperature that is currently used by the indoor unit as the reference of its own control loop.



NOTICE

Depending on the AC configuration, this value can be the temperature reported by:

- The sensor of the indoor unit.
- The sensor of the remote controller.



NOTE

Hitachi cannot guarantee the RoomTemperature object value is consistently equal to the actual room temperature. See [Virtual Temperature \(page 62\)](#).

- **RoomTemperature_command (Analog Output Object Type)**

This object allows us to provide an external temperature sensor from the BACnet side. Hitachi indoor units don't allow devices like this gateway to directly provide the temperature to be used as a reference of the control loop of the AC indoor unit. In order to overcome this limitation and enable the usage of an external temperature sensor (i.e., from the BACnet side), the IN485HIT001R000 gateway uses the virtual temperature mechanism. See [Virtual Temperature \(page 62\)](#).

- **Setpoint_status (Analog Input Object Type)**

This object shows the real temperature sent to the indoor unit. Its behavior depends on the *virtual temperature* function:

- If *virtual temperature* is disabled, its value will be the same as Setpoint_command.
- If *virtual temperature* is enabled, the value will be S_{AC} (AC setpoint), that is to say, the real setpoint modified by the virtual temperature's algorithm, as explained in [Virtual Temperature \(page 62\)](#).



NOTE

You can set the temperature scale in Celsius or Fahrenheit scale via DIP switches. More information in [DIP Switches \(page 9\)](#).

8. Modbus Application Specifications

The following sections provide the gateway's specifications when set as a Modbus RTU server device.

8.1. Implemented Modbus Functions

The IN485HIT001R000 gateway implements the following standard Modbus functions:

- 03: Read Holding Registers
- 04: Read Input Registers
- 06: Write Single Register
- 16: Write Multiple Registers



IMPORTANT

Even though function 16 is available, the gateway does not allow writing operations on more than one register with the same request, so the length field when using this function should always be one.

8.1.1. Modbus Physical Layer

The IN485HIT001R000 gateway implements a Modbus RTU (server) interface to be connected to an EIA-485 bus. It features an 8-N-2 communication (eight data bits, no parity, and two stop bits) with several available baud rates: 2400, 4800, **9600 -default-**, 19200, 38400, 57600, 76800, and 115200 bps. It also supports 8-N-1 communication (eight data bits, no parity, and one stop bit).



NOTE

AUTO-DETECT FUNCTION. The gateway will automatically detect the communication type (8-N-1 or 8-N-2) and set itself accordingly. No user action or manual settings are required.

8.1.2. Modbus Registers

Register name	Possible values	Register protocol address	Register PLC address	R/W
ON/OFF	0: Off 1: On	0	1	R/W
OPERATION MODE ¹	0: Auto 1: Heat 2: Dry 3: Fan 4: Cool	1	2	R/W
FAN SPEED ¹	0: Auto 1: Quiet 2: Low 3: Med 4: High	2	3	R/W
VANE U/D POSITION ¹	1: Position-1 (Horizontal) 2: Position-2 (Horizontal) 3: Position-3 (Medium) 4: Position-4 (Vertical) 10: Swing	3	4	R/W

Register name	Possible values	Register protocol address	Register PLC address	R/W
TEMPERATURE (USER) SETPOINT ^{1 2}	-32768 (Initialization value) 16 .. 30 (°C) (0: undetermined) 61 .. 86 (°F) (0: undetermined) More info in Considerations on Modbus Temperature Registers (page 61)	4	5	R/W
INDOOR UNIT REFERENCE TEMPERATURE ²	The values range is specific to the AC manufacturer.	5	6	R
WINDOW CONTACT PROTOCOL INPUT	0: Closed (default) 1: Open	6	7	R/W
CONTROL OBJECTS DISABLEMENT	It disables the control of the AC unit through the registers of the gateway. 0: Control objects enabled (default) 1: Control objects disabled  TIP Send a 0 to this register if, for any reason, the gateway doesn't work.	7	8	R/W
REMOTE CONTROL DISABLEMENT	It disables the control of the AC unit through any RC. 0: Remote control enabled (default) 1: Remote control disabled	8	9	R/W
OPERATION TIME (IN HOURS)	0 .. 65535	9	10	R/W
ALARM STATUS	0: No alarm condition 1: Alarm condition	10	11	R
ERROR CODE	0: No error present 65535 (-1 if it is read as a signed value): Communication error between the gateway or the remote controller and the AC unit. For any other value, see Error Codes (page 64)	11	12	R
OPEN WINDOW TIMEOUT (IN MINUTES)	0 .. 30	13	14	R/W
BAUDRATE	Baudrate currently selected via DIP switch SW2.	14	15	R
MODBUS SLAVE ADDRESS	1 .. 63	15	16	R
MAX NUM OF FANSPEEDS	3 .. 6	21	22	R
INPUT SENSOR TEMPERATURE ^{1 2}	 NOTE The indoor unit's ambient temperature is provided by an external sensor (on the Modbus side). -32768: (Initialization value). No temperature is provided by an external sensor. Any other value: Ambient temperature	22	23	R/W
AC REAL SETPOINT ^{1 2}	When no external temperature is provided, this read-only register will show the same value as register 5 (PLC addressing). In all cases, it will show the current setpoint in the indoor unit. 16 .. 31°C / 60 .. 92°F	23	24	R
ACTUAL AC MAX SETPOINT ^{1 2}	-32768 (Initialization value) The values range is specific to the AC manufacturer.	24	25	R
ACTUAL AC MIN SETPOINT ^{1 2}	-32768 (Initialization value) The values range is specific to the AC manufacturer.	25	26	R
WINDOW CONTACT FUNCTIONAL STATUS (FEEDBACK)	0: Not active (default) 1: Active (the window is open)	31	32	R
WIN CONTACT ON/OFF DISABLEMENT	0: Window contact is not disabling On/Off (it is not working). 1: Window contact is disabling On/Off (it is in use).	40	41	R

Register name	Possible values	Register protocol address	Register PLC address	R/W
FILTER RESET	1: Reset	43	44	W
FILTER STATUS	0: Off 1: On	44	45	R
ERROR RESET	1: Reset	45	46	W
SWITCH VALUE	DIP switches current value	48	49	R
ANTIFREEZE OPERATION	0: Disabled 1: Enabled	56	57	R/W
INPUT REFERENCE TEMPERATURE (Feedback) ¹ ₂	0x8000: No temperature is provided by an external sensor. No virtual temperature is being applied. Any other value: Temperature	65	66	R
RETURN PATH TEMPERATURE ^{1 2}	-32768 (Initialization value) The values range is specific to the AC manufacturer.	66	67	R
ERROR ADDRESS	It indicates the AC indoor unit address reporting the error	81	82	R
FILTER SIGNAL ADDRESS	It indicates the AC indoor unit address reporting the filter signal	86	87	R
FW version MSB	It shows the first two numbers of the firmware version. Example: For version 1.2.3.4, it will show 1.2 (in hexadecimal).	94	95	R
FW version LSB	It shows the last two numbers of the firmware version. Example: For version 1.2.3.4, it will show 3.4 (in hexadecimal).	95	96	R
MASTER/SLAVE	0: Slave 1: Master	98	99	R
RESET	1: Reset	99	100	W
VIRTUAL TEMP ACTIVE	0: No active 1: Active	129	130	R
WINDOW CONTACT STEP	0: Idle (window is closed). 1: Timeout1 (window is opened, timeout starts). 2: Timeout2 (it doesn't apply to window contact). 3: Window contact applies (window is opened, time is finished, window contact action is applied).	130	131	R
WINDOW CONTACT RELOAD LAST VALUE	0: No (default) 1: Yes	1000	1001	R/W
WINDOW CONTACT LOCK WHEN OPEN	0: No 1: Yes	1001	1002	R/W
WINDOW TIMEOUT (IN MINUTES)	0 .. 30	1002	1003	R/W
RESET BEHAVIOUR	0: Don't store AC or default status 1: Store current AC status (default) 2: Store default user AC status (MBS default AC registers) If the value is 0, the default values are: ON/OFF: OFF, Mode: Cool, SetTemp: 25°C, Fan speed: 1, Vanes position: 1	1100	1101	R/W
ONOFF DEFAULT	0: Off 1: On	1101	1102	R/W
USERMODE DEFAULT	0: Auto 1: Heat 2: Dry 3: Fan 4: Cool	1102	1103	R/W

Register name	Possible values	Register protocol address	Register PLC address	R/W
FANSP DEFAULT	0: Auto 1: Quiet 2: Low 3: Med 4: High	1103	1104	R/W
SETPTEMP DEFAULT	-32768 (Initialization value) 16 .. 30 (°C) (0: undetermined) 61 .. 86 (°F) (0: undetermined)	1104	1105	R/W
VANESUD DEFAULT	1: Position-1 (Horizontal) 2: Position-2 (Horizontal) 3: Position-3 (Medium) 4: Position-4 (Vertical) 10: Swing	1105	1106	R/W
MACHINE MODE	0: Normal (default) 1: Autochangeover 2: Limited setpoint	1150	1151	R/W
MACHINE MIN SETPOINT COOL	By default: 24°C / 75°F	1153	1154	R/W
MACHINE MAX SETPOINT COOL	°C/°F By default: 24°C / 75°F	1154	1155	R/W
MACHINE MIN SETPOINT HEAT	°C/°F By default: 28°C / 82°F	1155	1156	R/W
MACHINE MAX SETPOINT HEAT	°C/°F By default: 19°C / 66°F	1156	1157	R/W
REMOTE LOCK AFTER RESET	0: Remote lock is disabled after reset 1: It keeps the value set in register 8 (AC remote control disablement)	1220	1221	W
DEVICE IDENTIFIER	5120	2000	2001	R
MODE_MAP	See the Mode map table below	2001	2002	R
FAN_MAP	See the Fan map table below	2002	2003	R
VANES_MAP	See the Vanes map table below	2003	2004	R
U_D_VANES_MAP	See the Vanes U/D map table below	2004	2005	R
RUNTIME_MODE_RESTRICTIONS_MAP	See the Run time mode restrictions map table below	2012	2013	R

**NOTE**

¹ Available values may vary depending on the AC model.

² Set the temperature units via the DIP switch SW2: See [DIP Switches \(page 9\)](#).

Table 14. Mode map

Bit	Values
15	1: Invalid 0: Valid
14 .. 05	Not used
04	1: Cool mode enabled 0: Cool mode disabled
03	1: Fan mode enabled 0: Fan mode disabled
02	1: Dry mode enabled 0: Dry mode disabled

Bit	Values
01	1: Heat mode enabled 0: Heat mode disabled
00	1: Auto mode enabled 0: Auto mode disabled

Table 15. Fan map

Bit	Values
15	1: Invalid 0: Valid
14 .. 11	Not used
10	1: Fan 10 enabled 0: Fan 10 disabled
09	1: Fan 9 enabled 0: Fan 9 disabled
08	1: Fan 8 enabled 0: Fan 8 disabled
07	1: Fan 7 enabled 0: Fan 7 disabled
06	1: Fan 6 enabled 0: Fan 6 disabled
05	1: Fan 5 enabled 0: Fan 5 disabled
04	1: Fan 4 enabled 0: Fan 4 disabled
03	1: Fan 3 enabled 0: Fan 3 disabled
02	1: Fan 2 enabled 0: Fan 2 disabled
01	1: Fan 1 enabled 0: Fan 1 disabled
00	1: Fan auto enabled 0: Fan auto disabled

Table 16. Vanes map

Bit	Values
15	1: Invalid 0: Valid
14 .. 04	Not used
03	1: Pulse L/R enabled 0: Pulse L/R disabled
02	1: Pulse U/D enabled 0: Pulse U/D disabled
01	1: Specific L/R enabled 0: Specific L/R disabled (value of LR register doesn't matter)
00	1: Specific U/D enabled 0: Specific U/D disabled (see UD register as generic vane bitfield)

Table 17. Vanes UD map

Bit	Values
15	1: Invalid 0: Valid
14, 13	Not used
12	1: Wide enabled 0: Wide disabled
11	1: Swirl enabled 0: Swirl disabled
10	1: Swing enabled 0: Swing disabled
09	1: Position 9 enabled 0: Position 9 disabled
08	1: Position 8 enabled 0: Position 8 disabled
07	1: Position 7 enabled 0: Position 7 disabled
06	1: Position 6 enabled 0: Position 6 disabled
05	1: Position 5 enabled 0: Position 5 disabled
04	1: Position 4 enabled 0: Position 4 disabled
03	1: Position 3 enabled 0: Position 3 disabled
02	1: Position 2 enabled 0: Position 2 disabled
01	1: Position 1 enabled 0: Position 1 disabled
00	1: Auto/Off enabled 0: Auto/Off disabled

Table 18. Run time mode restrictions map

Bit	Values
15	1: Invalid 0: Valid
14 .. 05	Not used
04	1: Cool mode not writable 0: Cool mode writable
03	1: Fan mode not writable 0: Fan mode writable
02	1: Dry mode not writable 0: Dry mode writable
01	1: Heat mode not writable 0: Heat mode writable
00	1: Auto mode not writable 0: Auto mode writable

8.2. Considerations on Modbus Temperature Registers

- **AC unit Temperature Setpoint (R/W) (register 5 – in PLC addressing)**

This is the temperature setpoint requested by the user. This register can be read (Modbus functions 3 or 4) or written (Modbus functions 5 or 16). A remote controller connected to the three-wire bus of the AC indoor unit will report the same temperature setpoint value as this register.

- **AC unit external reference temperature (R/W) (register 23 – in PLC addressing)**

This register allows for providing an external temperature reference from the Modbus side. If an external temperature is provided through this register, the indoor unit will use it as the reference for its temperature control loop.

- The register value after the gateway startup is -32768, which means that no temperature reference is provided to the AC indoor unit. In that case, the AC indoor unit will use its own return path temperature sensor as the reference for its control loop.



NOTE

Temperature values are expressed according to the DIP switch configuration (see [DIP switches](#)). The following formats are possible:

- **Celsius:** the temperature value is in Celsius (a value “22” in the Modbus register must be interpreted as 22°C).
- **Tenths of value:** the temperature value is Nx10 (a value “220” in the Modbus register must be interpreted as 22.0°C).
- **Fahrenheit:** the temperature value is in Fahrenheit (a value “72” in the Modbus register must be interpreted as 72°F).

9. Virtual Temperature

Air conditioners are usually installed higher than the control system temperature sensors (and higher than the room occupants too). This creates a difference between the real temperature at which the AC unit operates and the temperature perceived by the sensor and the people in the room.

Example

Imagine a room where:

- The AC unit operates at 28°C.
- The control system sensor perceives a temperature of 24°C.

The user decides to lower the temperature and sets it at 21°C.

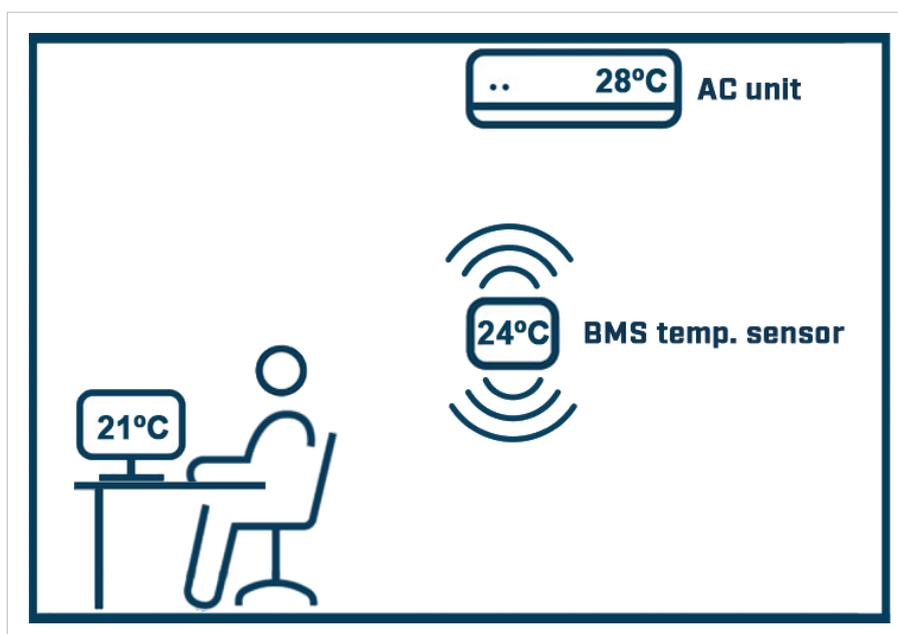

Without the virtual temperature function, the AC unit lowers the temperature by 7°C to match the 21°C the user desires (28-7), but what the user actually gets is 17°C (24-7).

The virtual temperature function applies a formula to make the AC unit operate at the appropriate temperature:

$$S_{BMS} - (T_{BMS} - T_{AC}) = S_{AC}$$

Where:

S_{BMS} (BMS setpoint): Temperature set by the user from the BMS protocol.

T_{BMS} (BMS temperature): Ambient temperature set by the user from the BMS protocol.

T_{AC} (AC temperature): Ambient temperature in the AC system (also known as AC reference temperature).

S_{AC} (AC setpoint): Temperature setpoint in the AC system.

So, applying the virtual temperature formula, we have:

$$21 - (24 - 28) = S_{AC}$$

$$21 - (-4) = S_{AC}$$

$$25 = S_{AC}$$

Activating the virtual temperature function, the AC unit does not lower the temperature by 7°C, but only 3°C. This way, it operates at 25°C, and both the sensor and the user perceive the desired temperature of 21°C.



IMPORTANT

Once the virtual temperature is active, it's no longer possible to write the setpoint temperature from the HVAC side, neither through the remote controller, the AC unit, or any other device.



NOTICE

The virtual temperature function is very useful in some situations, but not desirable in others.

You may use it when:

- The temperature the AC unit provides differs from the temperature perceived in the room.
- There are no temperature sensors in the room.
- Although actually there are, it is not possible to configure the temperature they measure as the AC unit reference temperature.

10. Error Codes

10.1. Gateway Codes

Error Code	Error CodeM		Error in Controller	Error Category	Error Description
	Value	Text			
0	1	–	N/A	Intesis AC Interface	No active error
-1 (65535)	2	CommError	N/A	Intesis AC Interface	Error in the communication of Intesis AC Interface or the Remote Controller with the AC Unit
-3	3	MainSub RC Settings	N/A	Indoor Unit	Tripping of Protection Device
-4	4	Initialization	N/A	Outdoor Unit	Tripping of Protection Device

10.2. AC System Codes

Error Code	Error CodeM		Error in Controller	Error Category	Error Description
	Value	Text			
1	5	E-01	1	Indoor Unit	Tripping of Protection Device
2	6	E-02	2	Outdoor Unit	Tripping of Protection Device
3	7	E-03	3	Transmission	Abnormality between Indoor and Outdoor
4	8	E-04	4	Inverter	Abnormality between Inverter and Control PCB
5	9	E-05	5	Transmission	Abnormality in Power Source Wiring
6	10	E-06	6	Voltage drop	Fan motor locked, overload, over current
			6.		Swing flap motor error
7	11	E-07	7	Cycle	Overcurrent of AC input
8	12	E-08	8		Electronic expansion valve drive error
9	13	E-09	9	Outdoor Unit	Heater overheat
17	14	E-11	11	Sensor on Indoor Unit	Dust collector error / No-maintenance filter error
18	15	E-12	12		Capacity setting error (indoor)
19	16	E-13	13		Shortage of water supply
20	17	E-14	14		Malfunctions of a humidifier system (water leaking)
25	18	E-19	19		Malfunctions in a sensor system
33	19	E-21	21	Sensor on Outdoor Unit	Sensor system of drain water error
34	20	E-22	22		Heat exchanger (1) (Liquid pipe) thermistor system error
35	21	E-23	23		Heat exchanger (1) (Gas pipe) thermistor system error
36	22	E-24	24		Sensor system error of fan motor locked, overload
41	23	E-29	29		Sensor system of swing flap motor error
48	24	E-30	30		Sensor system of over-current of AC input
49	25	E-31	31		Suction air thermistor error

50	26	E-32	32		Discharge air thermistor system error
53	27	E-35	35		Contamination sensor error
54	28	E-36	36		Humidity sensor error
56	29	E-38	38		Remote control thermistor error
57	30	E-39	39		Radiation sensor error
67	31	E-43	43	Pressure	High pressure switch sensor
68	32	E-44	44		Protection devices activated
69	33	E-45	45		Outdoor unit PCB assembly failure
70	34	E-46	46		High pressure switch (HPS) activated
71	35	E-47	47		Low pressure switch (LPS) activated
81	36	E-51	51	Inverter	Overload of inverter compressor motor
82	37	E-52	52		Over current of STD compressor motor
83	38	E-53	53		Overload of fan motor / Over current of fan motor
84	39	E-54	54		Overcurrent of AC input
86	40	E-56	56	Outdoor Fan	Electronic expansion valve drive error
87	41	E-57	57		Four-way valve error
88	42	E-58	58		Pump motor over current
176	44	E-B0	b0	IU model setting	Incorrect setting address or refrigerant cycle
177	43	E-B1	b1	Number setting	Incorrect setting address or refrigerant cycle
181	44	E-B5	b5		Incorrect setting of indoor unit number for H- LINK type
238	45	E-EE	EE	Inverter	Water temperature abnormal

**NOTE**

If you detect a non-listed error code, please contact Hitachi technical support.